



30K-3P-208V

WIRING DIAGRAMS





DISCLAIMER

The following diagrams are general use cases. Installers are reminded that adherence to local electrical codes and regulations is mandatory. While these diagrams offer general guidance, they may not encompass all variations and specifics required by local codes. Consult with relevant authorities and ensure compliance before proceeding with any installation. The diagrams presented herein are not exhaustive and should not be relied upon solely for permitting or warranty verification. Installers are encouraged to exercise caution, seek professional advice when necessary, and undertake installations with due diligence and in accordance with established electrical standards and regulations.

Standard Wiring Diagram

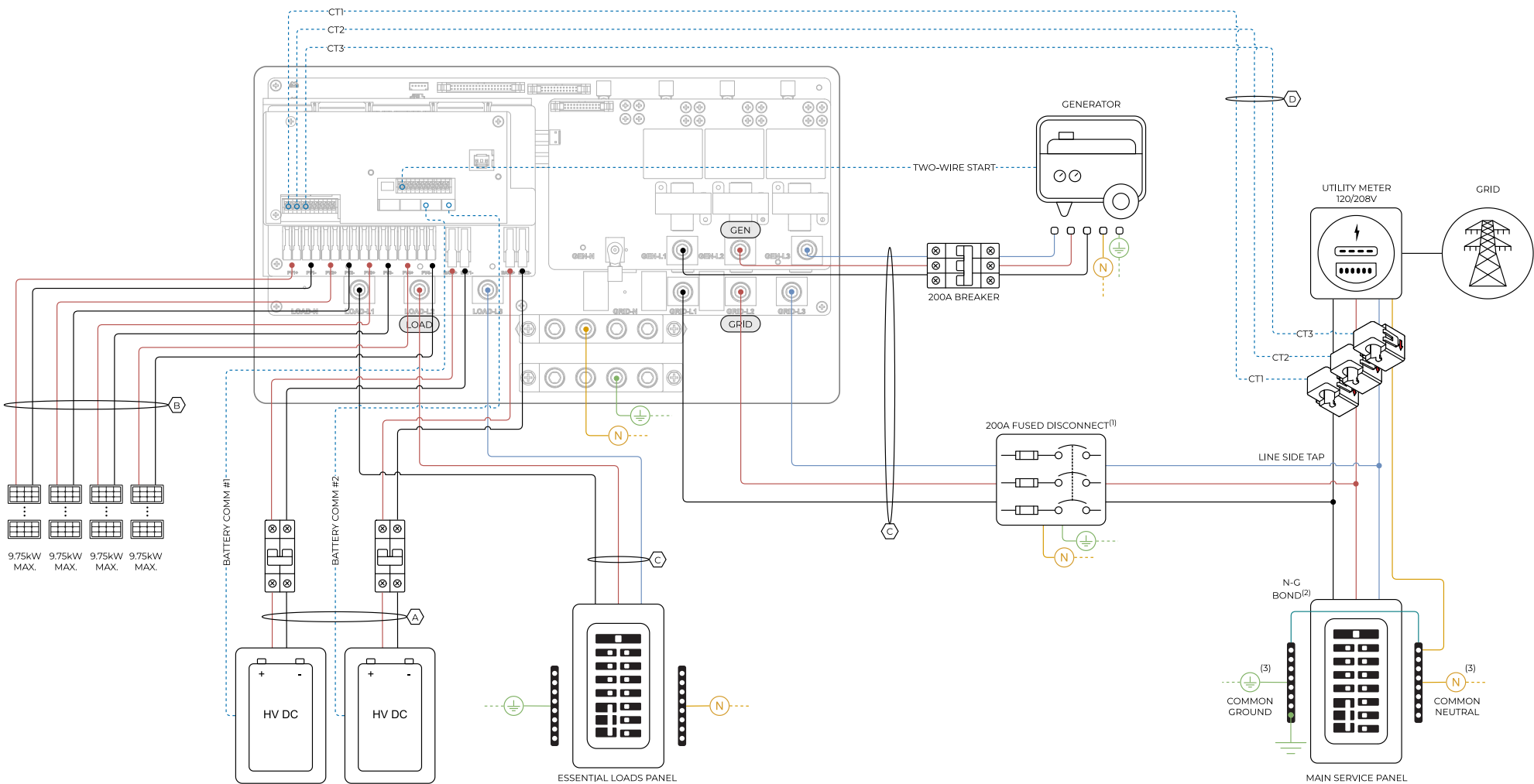

— L1 - (AC) NEGATIVE - (DC)
 — L2 - (AC) POSITIVE - (DC)
 — L3
 — NEUTRAL
 — GROUND
 — SENSORS / COMMUNICATIONS

(1) LOCATION OF THE NEUTRAL-GROUND BOND WILL DEPEND ON LOCAL CODE
 (2) THESE SYMBOLS REPRESENT A COMMON NEUTRAL / GROUND CONNECTION. **DO NOT** CONFUSE WITH GROUNDING ROD



WIRE GAUGE GUIDE (COPPER)

LABEL	CONDUCTOR
A	MAX. 4 AWG
B	MAX. 10 AWG
C	MAX. 4 AWG
D	24 - 23 AWG CAT6

Diagram 01

Standard Wiring Diagram - Line Side Tap

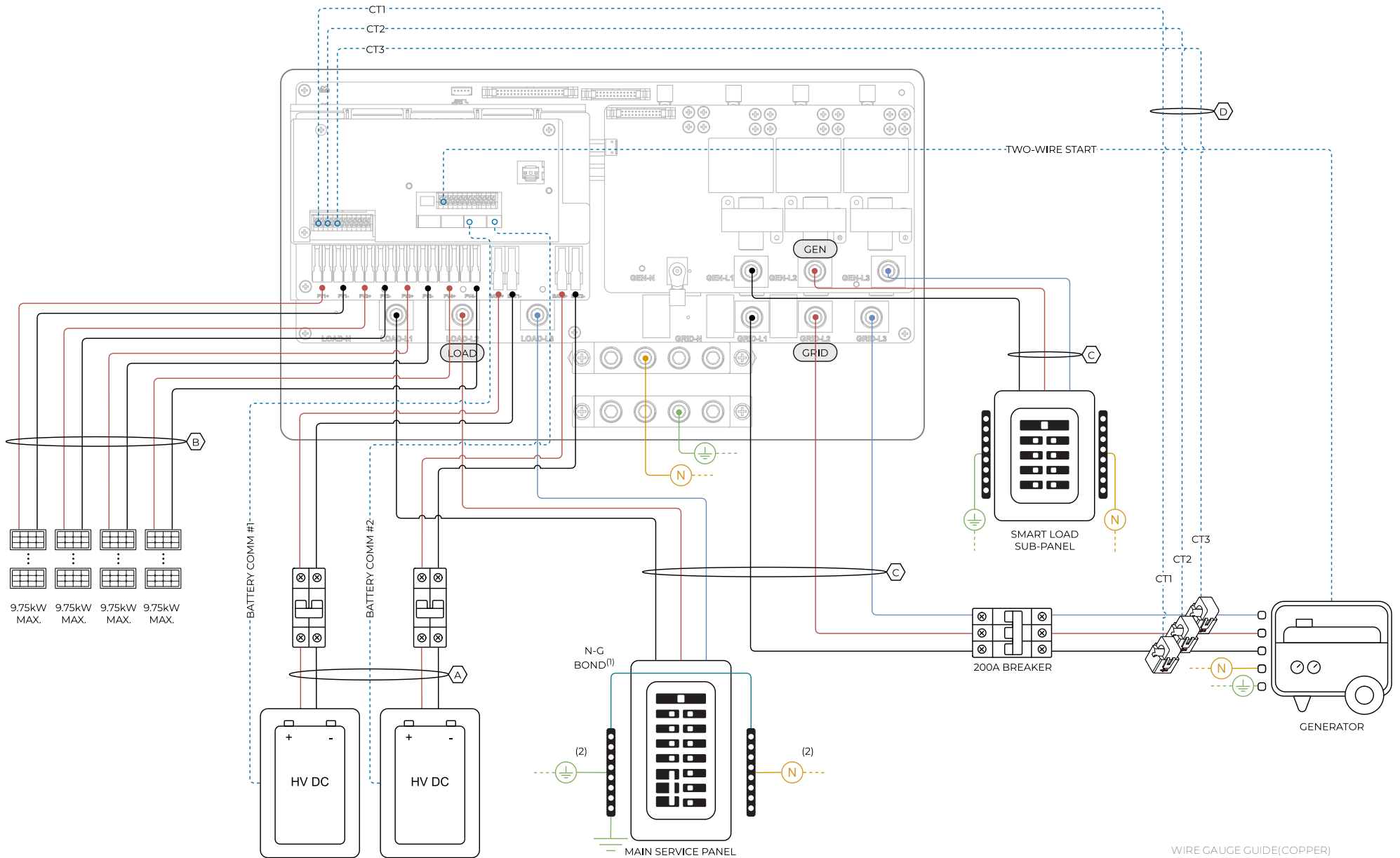

— L1 - (AC) NEGATIVE - (DC)
 — L2 - (AC) POSITIVE - (DC)
 — L3
 — NEUTRAL
 — GROUND
 — SENSORS / COMMUNICATIONS

- (1) SIZE OF DISCONNECT WILL DEPEND ON REQUIRED PASSTHROUGH CURRENT AND LOCAL CODE REQUIREMENTS
- (2) LOCATION OF THE NEUTRAL-GROUND BOND WILL DEPEND ON LOCAL CODE
- (3) THESE SYMBOLS REPRESENT A COMMON NEUTRAL / GROUND CONNECTION. **DO NOT** CONFUSE WITH GROUNDING ROD



WIRE GAUGE GUIDE (COPPER)

LABEL	CONDUCTOR
A	MAX. 4 AWG
B	MAX. 10 AWG
C	MAX. 4 AWG
D	24 - 23 AWG CAT6

Diagram 02

Standard Wiring Diagram - AC Coupling

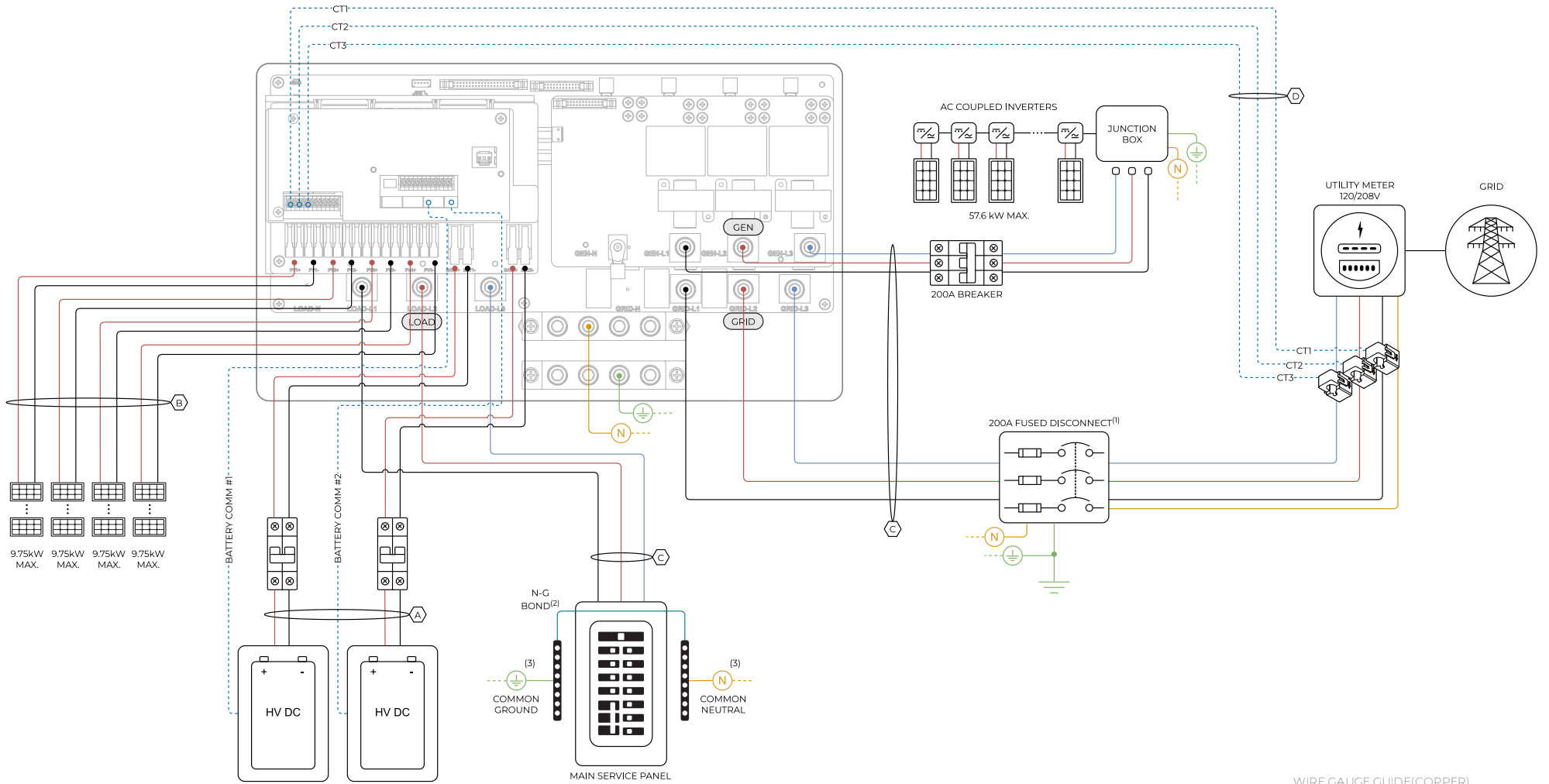

— L1 - (AC) NEGATIVE - (DC)
 — L2 - (AC) POSITIVE - (DC)
 — L3
 — NEUTRAL
 — GROUND
 — SENSORS / COMMUNICATIONS

- (1) SIZE OF DISCONNECT WILL DEPEND ON REQUIRED PASSTHROUGH CURRENT AND LOCAL CODE REQUIREMENTS
- (2) LOCATION OF THE NEUTRAL-GROUND BOND WILL DEPEND ON LOCAL CODE
- (3) THESE SYMBOLS REPRESENT A COMMON NEUTRAL / GROUND CONNECTION. **DO NOT** CONFUSE WITH GROUNDING ROD



WIRE GAUGE GUIDE(COPPER)

LABEL	CONDUCTOR
A	MAX. 4 AWG
B	MAX. 10 AWG
C	MAX. 4 AWG
D	24 - 23 AWG CAT6

Diagram 03

Standard Wiring Diagram - Bypass Transfer Switch

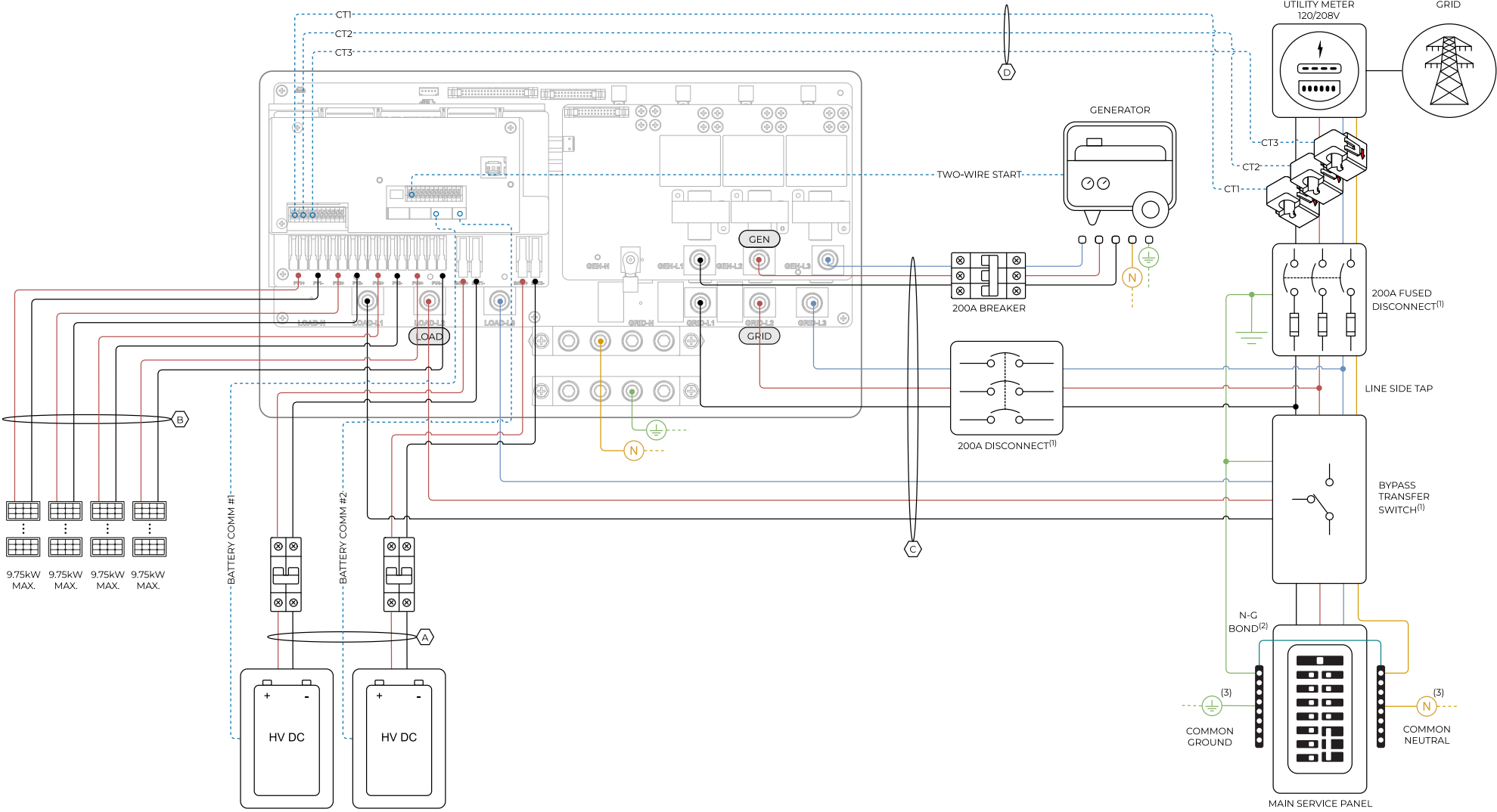

— L1 - (AC) NEGATIVE - (DC)
 — L2 - (AC) POSITIVE - (DC)
 — L3
 — NEUTRAL
 — GROUND
 — SENSORS / COMMUNICATIONS

- (1) SIZE OF DISCONNECT WILL DEPEND ON REQUIRED PASSTHROUGH CURRENT AND LOCAL CODE REQUIREMENTS
- (2) LOCATION OF THE NEUTRAL-GROUND BOND WILL DEPEND ON LOCAL CODE
- (3) THESE SYMBOLS REPRESENT A COMMON NEUTRAL / GROUND CONNECTION. **DO NOT** CONFUSE WITH GROUNDING ROD



WIRE GAUGE GUIDE(COPPER)

LABEL	CONDUCTOR
A	MAX. 4 AWG
B	MAX. 10 AWG
C	MAX. 4 AWG
D	24 - 23 AWG CAT6

Standard Wiring Diagram - Standby Generator

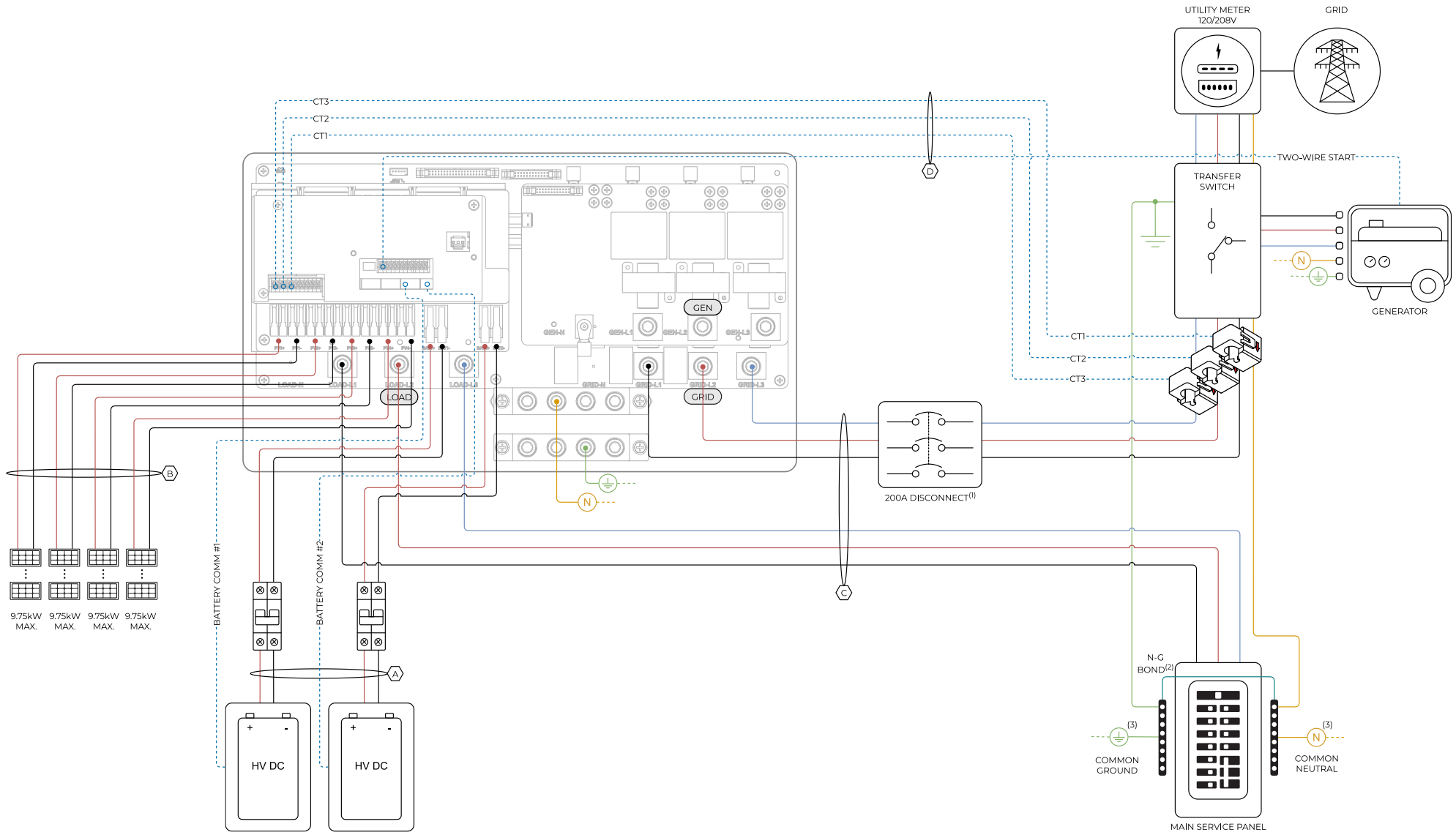

— L1 - (AC) — L2 - (AC) — L3 — NEUTRAL — GROUND — SENSORS / COMMUNICATIONS
— NEGATIVE - (DC) — POSITIVE - (DC)

- (1) SIZE OF DISCONNECT WILL DEPEND ON REQUIRED PASSTHROUGH CURRENT AND LOCAL CODE REQUIREMENTS
- (2) LOCATION OF THE NEUTRAL-GROUND BOND WILL DEPEND ON LOCAL CODE
- (3) THESE SYMBOLS REPRESENT A COMMON NEUTRAL / GROUND CONNECTION. **DO NOT** CONFUSE WITH GROUNDING ROD



WIRE GAUGE GUIDE (COPPER)	
LABEL	CONDUCTOR
A	MAX. 4 AWG
B	MAX. 10 AWG
C	MAX. 4 AWG
D	24 - 23 AWG CAT6

Standard Wiring Diagram - Grid-Tie Only with Standby Generator

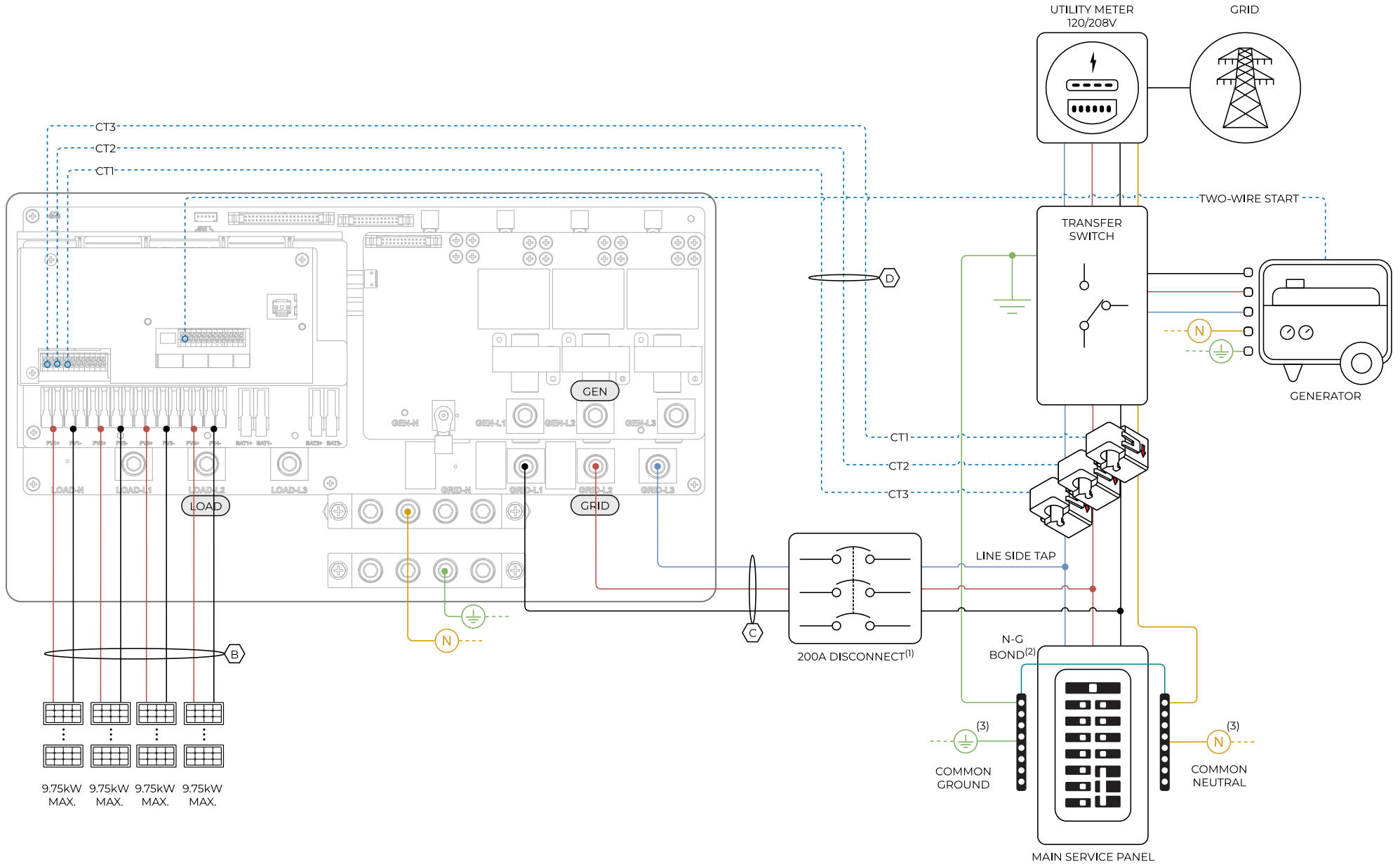

9.75kW MAX. 9.75kW MAX. 9.75kW MAX. 9.75kW MAX.

— L1 - (AC) NEGATIVE - (DC)
 — L2 - (AC) POSITIVE - (DC)
 — L3
 — NEUTRAL
 — GROUND
 — SENSORS / COMMUNICATIONS

- (1) SIZE OF DISCONNECT WILL DEPEND ON REQUIRED PASSTHROUGH CURRENT AND LOCAL CODE REQUIREMENTS
- (2) LOCATION OF THE NEUTRAL-GROUND BOND WILL DEPEND ON LOCAL CODE
- (3) THESE SYMBOLS REPRESENT A COMMON NEUTRAL / GROUND CONNECTION. **DO NOT** CONFUSE WITH GROUNDING ROD



WIRE GAUGE GUIDE(COPPER)

LABEL	CONDUCTOR
A	MAX. 4 AWG
B	MAX. 10 AWG
C	MAX. 4 AWG
D	24 - 23 AWG CAT6

Diagram 06

Standard Wiring Diagram - 2 Parallel Inverters, Standard Wiring

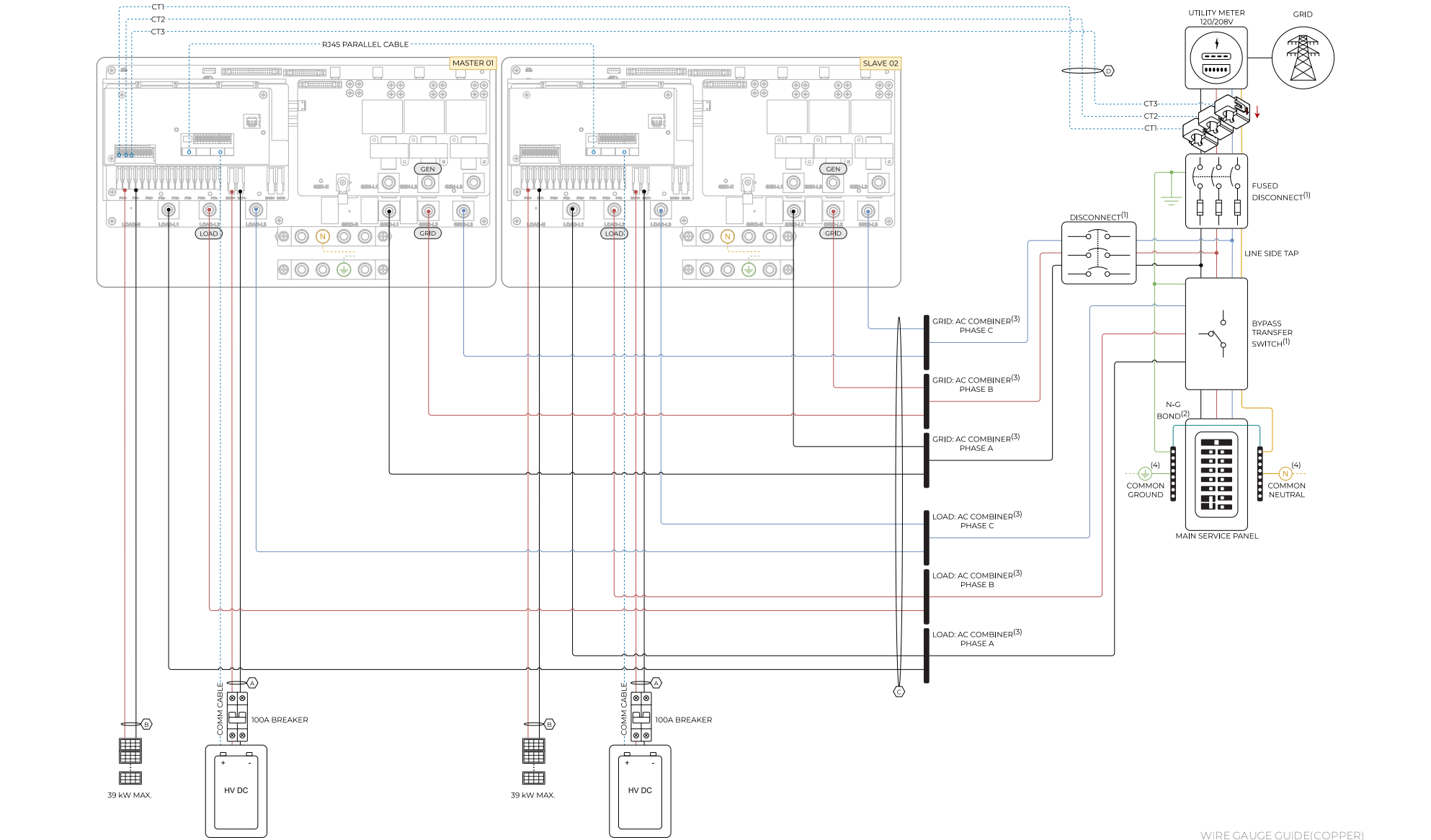

— L1 - (AC) NEGATIVE - (DC)
 — L2 - (AC) POSITIVE - (DC)
 — L3
 — NEUTRAL
 — GROUND
 — SENSORS / COMMUNICATIONS

- (1) SIZE OF DISCONNECT / BYPASS SWITCH WILL DEPEND ON REQUIRED PASSTHROUGH CURRENT AND LOCAL CODE REQUIREMENTS
- (2) LOCATION OF THE NEUTRAL-GROUND BOND WILL DEPEND ON LOCAL CODE
- (3) SMALL COMBINER PANEL CAN BE USED TO COMBINE PHASES AND AS A MEAN OF INDIVIDUAL SYSTEM DISCONNECTION
- (4) THESE SYMBOLS REPRESENT A COMMON NEUTRAL / GROUND CONNECTION. **DO NOT** CONFUSE WITH GROUNDING ROD



WIRE GAUGE GUIDE (COPPER)

LABEL	CONDUCTOR
A	MAX. 4 AWG
B	MAX. 10 AWG
C	MAX. 4 AWG
D	24 - 23 AWG CAT6

Diagram 07

Before powering up Parallel System installs, please see section 5 "Parallel Systems"

Standard Wiring Diagram - 3 Parallel Inverters, Standard Wiring

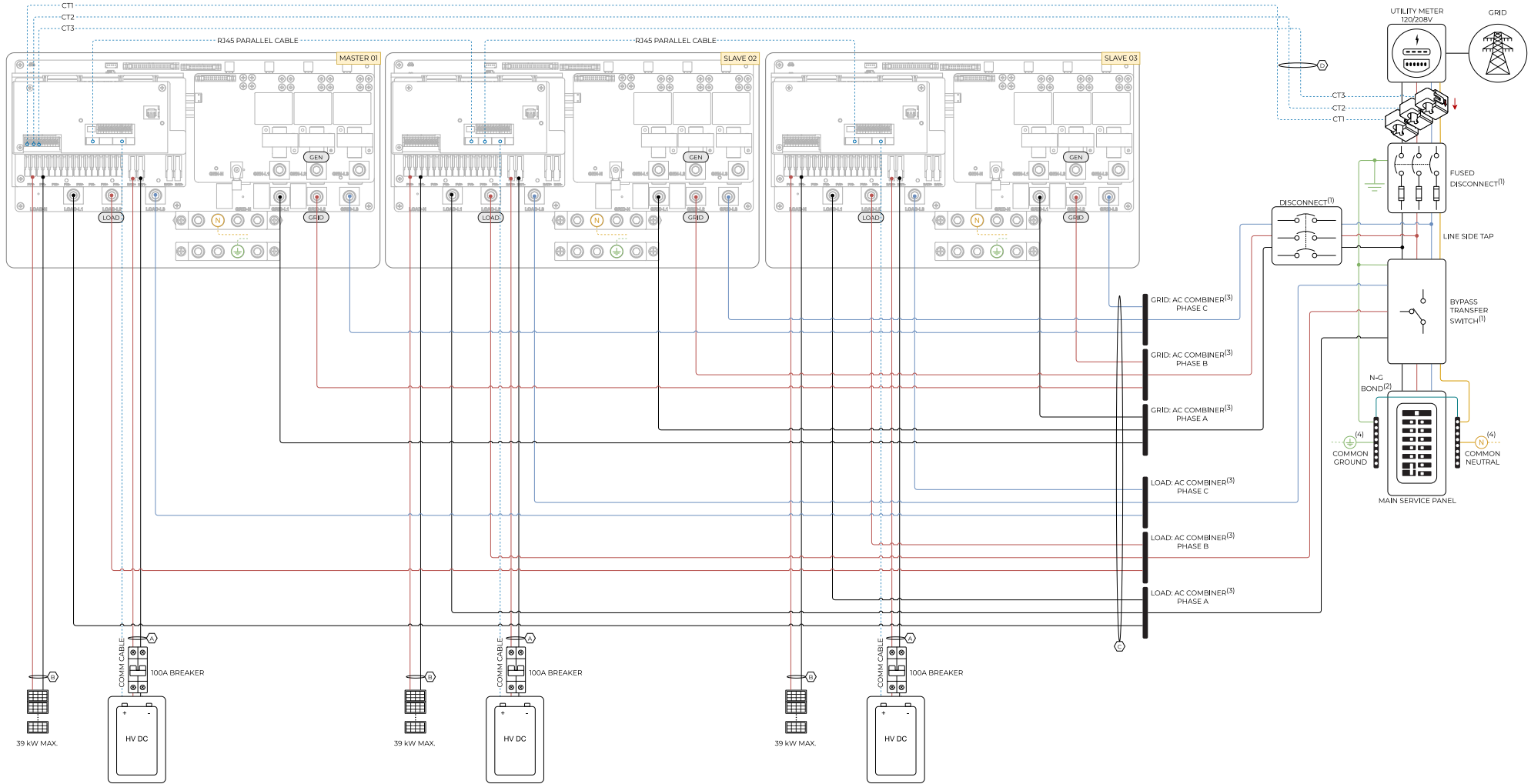

■ L1 - (AC) NEGATIVE - (DC)
 ■ L2 - (AC) POSITIVE - (DC)
 ■ L3
 ■ NEUTRAL
 ■ GROUND
 ■ SENSORS / COMMUNICATIONS

- (1) SIZE OF DISCONNECT / BYPASS SWITCH WILL DEPEND ON REQUIRED PASSTHROUGH CURRENT AND LOCAL CODE REQUIREMENTS
- (2) LOCATION OF THE NEUTRAL-GROUND BOND WILL DEPEND ON LOCAL CODE
- (3) SMALL COMBINER PANEL CAN BE USED TO COMBINE PHASES AND AS A MEAN OF INDIVIDUAL SYSTEM DISCONNECTION
- (4) THESE SYMBOLS REPRESENT A COMMON NEUTRAL / GROUND CONNECTION. **DO NOT** CONFUSE WITH GROUNDING ROD



WIRE GAUGE GUIDE(COPPER)

LABEL	CONDUCTOR
A	MAX. 4 AWG
B	MAX. 10 AWG
C	MAX. 4 AWG
D	24 - 23 AWG CAT6

Diagram 08

! Before powering up Parallel System installs, please see section 5 "Parallel Systems"