



INSTALLATION GUIDE
AND USER MANUAL

Sol-Ark 60K-3P-480V

COMMERCIAL & INDUSTRIAL
NORTH AMERICA

Effective Date: May 13, 2026





READ THE INSTRUCTIONS COMPLETELY BEFORE OPERATING THE EQUIPMENT



- Check the utility voltage before turning ON the unit.
- Verify the inverter's programmed grid type before connecting to the utility.
- The unit is programmed in 277/480V 3-Phase at 60Hz by default.
- Disregarding these instructions could result in permanent damage to the unit.

Information included in this Installation Guide speaks only as of the Effective Date and is qualified, in its entirety, by the Disclaimer referred to below and by the terms of any applicable Limited Warranty. Sol-Ark reserves the right to make product modifications at any time without advance notice, which may affect information included in this Installation Guide or otherwise make this information inapplicable and out-of-date.

For the latest Sol-Ark product and installation documents, visit: sol-ark.com

For errors, omissions, or suggestions, contact support@sol-ark.com

Disclaimer

UNLESS SPECIFICALLY AGREED TO IN WRITING BY SOL-ARK IN A VALIDLY EXECUTED AND DELIVERED CONTRACT:

Sol-Ark assumes no responsibility or liability for any damages, property loss, personal injury, or any adverse consequences resulting from improper use or installation of the product or the failure to adhere to the guidelines provided in this Installation Guide. Users are expressly advised to follow the instructions and guidelines outlined in the documentation accompanying the product. Sol-Ark is not be liable for any damages or losses incurred as a result of, or related to, any failure to comply with, or deviations from, recommended usage, installation, or maintenance procedures. By using the product, users acknowledge their understanding of these disclaimers and agree to use the product at their own risk. Sol-Ark reserves the right to update or modify product information, specifications, and guidelines without prior notice.

This Installation Guide is provided “as is,” without charge, and is intended solely for general informational purposes without any right or presumption of reliance. Your sole and exclusive remedy for any defects, or other issues associated with, or related to, any Sol-Ark product is limited and restricted solely to the Limited Warranty provided by Sol-Ark and included in any documentation provided by Sol-Ark or otherwise made available by Sol-Ark, whether through its website or otherwise. Failure to use the most recent, commercially available version of Sol-Ark software may void your warranty and may cause the performance or compatibility of your Sol-Ark product to be adversely affected. You are urged, at all times, to use the most recently available Sol-Ark software for any Sol-Ark product, including all updates, upgrades, and other modifications of that software made commercially available by Sol-Ark.

This Installation Guide is not intended to, and does not, supersede any instructions or directions that you may have received from the manufacturer of any other products that you may use in combination with a Sol-Ark. Sol-Ark makes no representation regarding energy system designs within which Sol-Ark products may be used, the use or integration of third party hardware or software with Sol-Ark products, or necessary compliance with local rules or regulations. Changes to non-Sol-Ark manufactured products, including to software or hardware components of those third-party products, may have a material effect on the performance of Sol-Ark products and could void applicable warranties or otherwise harm the performance of Sol-Ark products. To the fullest extent permitted by applicable law, Sol-Ark hereby expressly and unconditionally disclaims liability for any and all indirect, incidental, exemplary, punitive or consequential damages.

If you are uncertain about implementing or using any of the information contained in, or made available by, this Installation Guide, you are urged not to continue with this Installation Guide and immediately to contact Sol-Ark Technical Support. This Installation Guide does not modify, extend or change the terms of any Limited Warranty that may be applicable to your Sol-Ark products, and you should carefully consult those Limited Warranty terms to ensure that you may not be voiding or violating those Limited Warranty terms if you undertake any of the actions referred to in this Installation Guide.

Sol-Ark retains the right to final interpretation of this document and all related materials pertaining to this product. This document is subject to modifications, updates, revisions, or termination without prior notice. For the latest product information, please visit Sol-Ark’s official website. www.Sol-Ark.com

Any action related to the information included in this Installation Guide shall be governed by the internal laws of the State of Texas, United States of America, without giving effect to any conflicts of laws principles. Any action, suit, or other legal proceeding that is commenced to resolve any matter related to this Guide shall be commenced solely and exclusively in a state court sitting in Collin County, Texas (or, if appropriate, a federal court located within Collin County in the Eastern District of Texas), and you hereby consent to the personal jurisdiction of those courts.

This manual is for only the inverter labeled as: **60K-3P-480V Hybrid Inverter**.

For Sol-Ark Technical Support, contact:

(USA) +1 (972) 575-8875 ext. 2

support@Sol-Ark.com

Contents

Important Safety Instructions	vi
Symbols in this Document	vi
Product Recycling.....	vi
Notices	vii
1. Sol-Ark At First Glance.....	1
1.1 General Description	2
1.2 Specifications	3
1.3 Connection Requirements	5
2. Installation	7
2.1 Mounting the Sol-Ark	8
2.2 Integrating Batteries.....	11
2.3 Battery Communications.....	13
2.4 Connecting Solar PV to the Inverter.....	15
2.5 Integrating a Generator.....	17
2.6 Grid Peak Shaving.....	18
2.7 Automatic Generator Start	18
2.8 Integrating Sensors and Accessories.....	19
2.9 Connecting Current Transformers (CT Sensors).....	23
2.10 Emergency Stop and Rapid Shutdown (RSD).....	27
2.11 Electrical System Compatibility	29
2.12 Inverter Startup and Commissioning	31
2.13 Power Cycle Sequence.....	32
3. User Interface	33
3.1 LED Indicators	33
3.2 Main Menus	34
3.3 Basic Setup	37
3.4 Battery Setup.....	38
3.5 Limiter.....	41
3.6 Grid Setup	47
4. Installation Tips	50
4.1 Battery Charge Controller	51
4.2 Grid Compliance Settings	51
5. Parallel Inverters.....	52
5.1 Before Enabling Parallel Operations	52
5.2 Parallel Systems Programming	54
5.3 Troubleshooting Phase Sequence	55
6. MySolArk: Remote Monitoring.....	56
6.1 MySolArk Setup Instructions	56
6.2 LED Indicator and Troubleshooting.....	62



7. Wiring Diagrams.....	63
7.1 Standard Wiring Diagram.....	64
7.2 Standard Wiring Diagram – Off Grid	65
7.3 Standard Wiring Diagram – AC Coupling	66
7.4 Standard Wiring Diagram – Bypass Transfer Switch	67
7.5 Standard Wiring Diagram – Standby Generator	68
7.6 Standard Wiring Diagram – Grid-Tied Only with Standby Generator	69
7.7 Standard Wiring Diagram – 2 Parallel Inverters, Standard Wiring	70
7.8 Standard Wiring Diagram – 3 Parallel Inverters, Standard Wiring	71
8. Common Troubleshooting Steps.....	72
8.1 Sol-Ark Warning and Fault codes.....	75
9. Installation Checklist	77
10. Inverter UI Screens	78
10.1 Main Menu.....	78
10.2 Basic Setup	79
10.3 Batt Setup.....	80
10.4 Limiter.....	80
10.5 Grid Setup	81

Important Safety Instructions

This manual provides crucial information for installing and operating the 60K-3P-480V Hybrid Inverter System. Qualified and authorized personnel are required to perform the installation and maintenance procedures adhering to all safety standards and system requirements outlined in this document. Sol-Ark assumes no responsibility for damage caused to a Sol-Ark product by unauthorized or unqualified personnel.

This manual is applicable to countries that comply with the certification requirements. Standards and legal requirements of other countries might differ from the specifications outlined in this manual.

Symbols in this Document



WARNING: This symbol indicates information that, if ignored, could cause serious injury, equipment damage, or death.



CAUTION: This symbol indicates information that, if ignored, could result in minor injury or equipment damage.



NOTE: This symbol indicates relevant information that is not related to hazardous situations.

Product Recycling



- You must not attempt disposal via normal waste collection or abandon the inverter at a public facility.



- See the Sol-Ark website or call Sol-Ark Technical Support for more details as soon as you know your inverter has reached the end of its usable life



- For more information on locating recycling resources in your area, please visit our website at sol-ark.com/recycling.

Note on Dimmer Switches

The Sol-Ark inverter is designed to be compatible with most standard dimmer switches; however, compatibility may vary depending on the specific dimmer model and its settings. Light flickering, reduced performance, or improper dimming may occur when used with this inverter.

Notices

ATTENTION: Read all instructions and cautionary markings in this document and on the equipment before installing the Sol-Ark 60K-3P-480V. Failing to follow any of these instructions may result in equipment damage, electric shock, serious injury, or loss of life. Failing to follow any of these instructions may also void the limited warranty provided by Sol-Ark.

All installations must conform to the laws, regulations, codes and standards applicable in the jurisdiction of installation.

Before starting an installation, consult a local building or electrical inspector for current requirements. Local codes may vary but are adopted and enforced to promote safe electrical installations. A permit may be needed to do electrical work, and some codes may require an inspection of the electrical work. Sol-Ark is not responsible for system design or installation and makes no representations regarding system performance, reliability or compliance with local or other codes or requirements.

When installed in the US, electrical installations are required to follow the National Electrical Code (ANSI/NFPA 70) adopted by their local AHJ (Authority Having Jurisdiction) including any local amendments.

General

WARNING: Risk of electric shock. Risk of fire. Only qualified electrical personnel should install, troubleshoot, service, or replace the equipment.

WARNING: Risk of electric shock. Apply appropriate personal protective equipment (PPE) and follow safe electrical work practices during installation and service. Turn off all power supplying this equipment before working on or inside equipment and ensure that no charge remains in the equipment. Always use a properly rated voltage sensing device to confirm power is off. Replace all devices, covers, and doors before turning on power to the equipment.

WARNING: Inspect the equipment for damage before installation. Do not install the equipment if it has been damaged in any way.

WARNING: Do not insert foreign objects into any part of the equipment.

WARNING: Do not expose the equipment or any of its components to direct flame.

WARNING: Do not attempt to open, disassemble, repair, tamper with, or modify the equipment other than what is expressly permitted in this manual. The equipment contains no user-serviceable parts. Contact the installer who installed the equipment for any repairs.

WARNING: Do not connect life-support systems, other medical equipment, or any other use where product failure could lead to injury to persons or loss of life.

CAUTION: Do not use solvents to clean the equipment or expose the equipment to flammable or harsh chemicals or vapors. Do not allow petroleum-based paints, solvents, or sprays to contact nonmetallic parts of the equipment.

CAUTION: Do not use parts or accessories other than those specified for use with the equipment.



Installation and Use

WARNING: Risk of electric shock. Risk of fire. Only use electrical system components approved for dry locations.

WARNING: Risk of electric shock. Risk of fire. Ensure that all wiring is correct and that none of the wires are pinched or damaged.

WARNING: Risk of electric shock. Risk of fire. Before making any connections verify that the DC disconnect(s) are in the off position. Double check all wiring before applying power.

WARNING: Risk of electric shock. Improper servicing of the equipment or its components may result in a risk of shock or fire. To reduce these risks, disconnect all wiring before attempting any maintenance or cleaning.

WARNING: Risk of electric shock. Always de-energize the equipment before servicing.

WARNING: Risk of electric shock. Do not use equipment in a manner not specified by the manufacturer. Doing so may cause injury or loss of life, or damage to equipment.

CAUTION: Risk of damage. DO NOT connect the grid to the "LOAD" output terminal.

CAUTION: Risk of damage. Do not exceed **1,000Voc** on any MPPT on the 60K-3P-480V.

CAUTION: Risk of damage or electric shock. All inverter inputs should only have one conductor connected to them.

NOTE: This device complies with part 15 of the FCC Rules. Operation is subject to the following two conditions:

- This device may not cause harmful interference.
- This device must accept any interference received, including interference that may cause undesired operation. Changes or modifications not expressly approved by the party responsible for compliance could void the user's authority to operate the equipment.

Environmental Conditions

WARNING: This equipment is intended for operation in an environment having a minimum temperature of -40°C (-40°F) and a maximum temperature of 60°C (140°F).

WARNING: Install the equipment in a location that prevents damage from flooding. Ensure that no water sources are above or near the equipment, including downspouts, sprinklers, or faucet.

Transportation and Handling

WARNING: To protect the equipment and its components from damage when transporting, handle with care. To help prevent damage, leave all equipment in its shipping packaging until it is ready to be installed.

WARNING: Risk of physical injury or death. Use caution when using lifting equipment to move battery modules and components.

WARNING: Risk of physical injury or death. Boxed battery modules.

Requirements for Installation Personnel

All work MUST comply with local code, regulations, and industry standards. The installation of the 60K-3P-480V can only be completed by qualified people with appropriate qualifications as determined by the local AHJ

1. Sol-Ark At First Glance

Inspect Shipment

The box should include all items shown in the component guide. If there is damage or missing parts, immediately call the phone number (USA) +1 (972) 575-8875 ext. 2.

Component Guide

The Sol-Ark 60K-3P-480V system includes the following components:

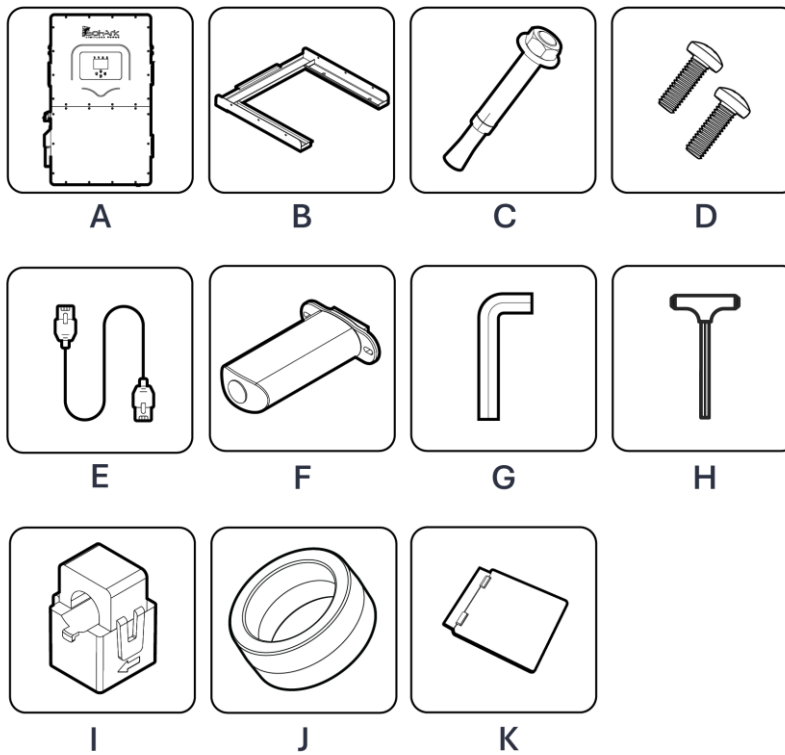

Component	Description	Quantity
A	Sol-Ark 60K-3P-480V inverter	1
B	Inverter Mounting Cleat	1
C	M12x60mm expanding anchors for masonry anchoring	4
D	M4x12mm screws – Set screws for mounting carrier	9
E	Inverter Parallel Cable - CAT 5E Communication cable	1
F	Wi-Fi / Ethernet Gateway (dongle)	1
G	3mm Allen hex key for front panel screws	1
H	8mm T-type hex key for AC terminals	1
I	300A Current transformers (CT sensors)	3
J	Filter rings	3
K	LCD Sunshade (for outside installations)	1

1.1 General Description

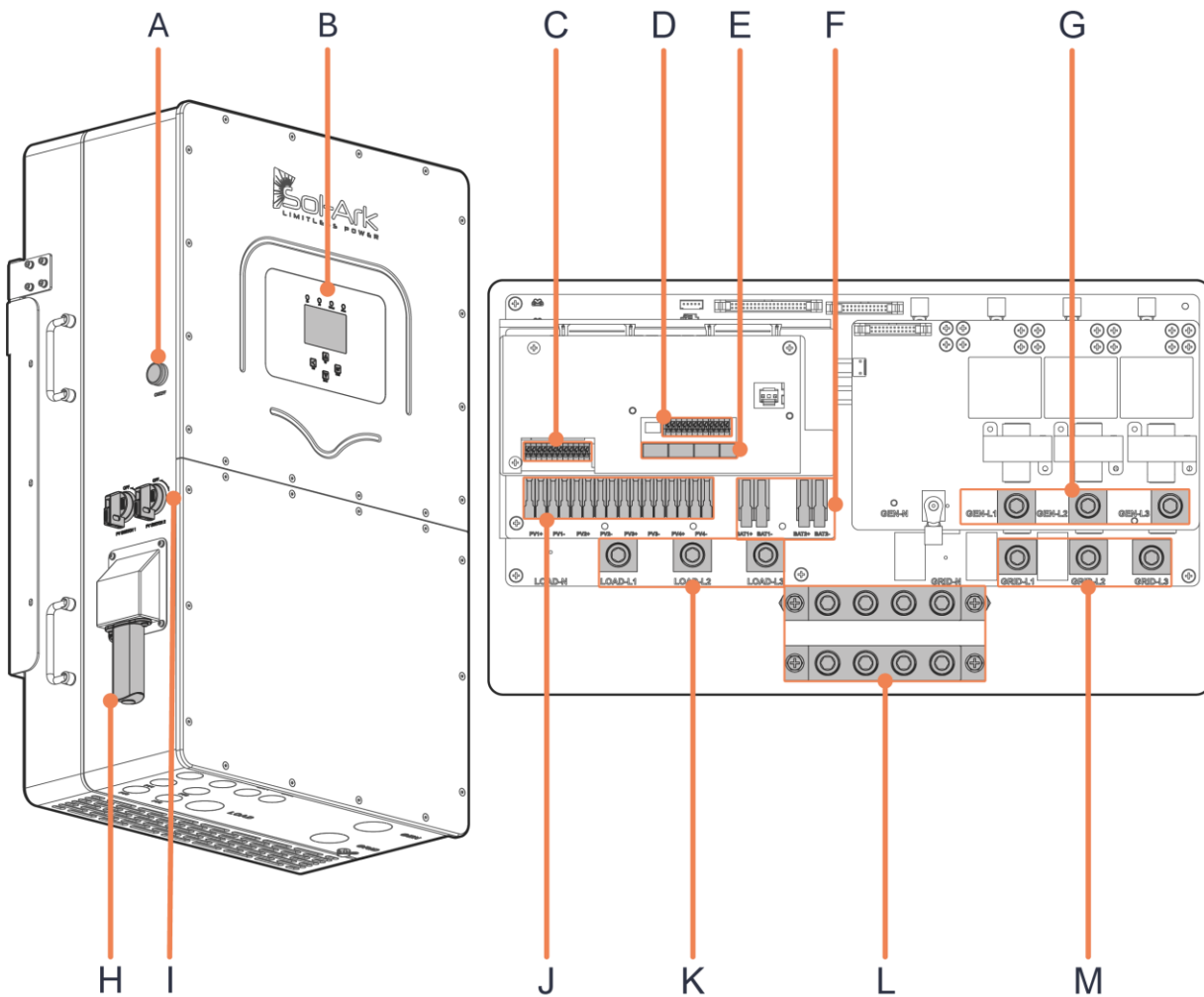

Component	Name	Component	Name
A	ON / OFF Button	H	Wi-Fi / Ethernet Gateway
B	LCD touch screen	I	2x PV DC disconnects
C	CN1 - Terminal block for sensors and accessories	J	4x MPPT inputs terminals
D	CN2 - Terminal block for sensors and accessories	K	(200A) LOAD terminal
E	Communication Ports	L	NEUTRAL / GROUND Busbars
F	2x (50A) Battery port	M	(200A) GRID terminal
G	(200A) GEN terminal		

1.2 Specifications

Note: Temperature Derating Starts at 75°C with inverter shutdown at 82°C

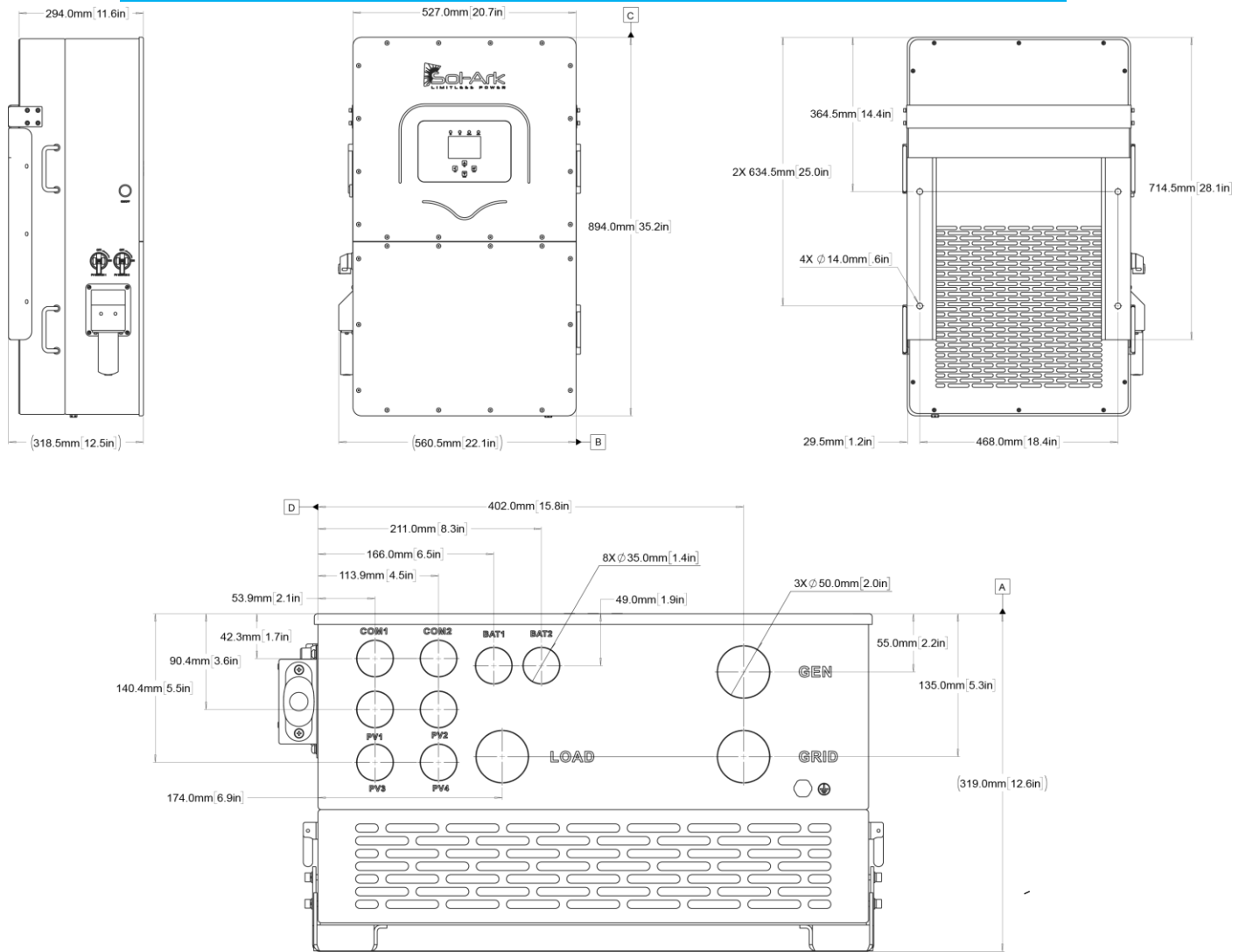

Sol-Ark 60K-3P-480V Fastener Torque Table

Warning: Do not use impact drivers to tighten any fasteners on the inverter

Terminal / Breaker	Torque [ft-lb]	Torque [Nm]
LOAD	18.75 ft-lb	25.5 Nm
GRID	18.75 ft-lb	25.5 Nm
GEN	18.75 ft-lb	25.5 Nm
Neutral / Ground (Busbar)	18.75 ft-lb	25.5 Nm
Cover Screws	15.5 in-lb	1.75 Nm
Battery Terminals	Push-in Cage Clamp	Push-in Cage Clamp



DATASHEET

60K-480V

SKU: 60K-3P-480V

60K-3P-480V C&I Hybrid Inverter

Input Data (PV)	
Max. Allowed PV Power (STC)	78,000W
MPPT Voltage Range	150-850V
Startup Voltage	180V
Max. Input Voltage ¹	1,000V
Max. operating input current per MPPT	36A
Max. short circuit current per MPPT	55A
No. of MPP Trackers	4
No. of PV Strings per MPPT	2
Max. AC Coupled Input	60,000W
Output Data (AC)	
Nominal AC Voltage (3Φ) ²	277/480V (4-wire Wye) or 480V (3-wire Delta)
Grid Frequency	50 / 60Hz
Real Power, max continuous (3Φ)	60,000W
Max. Output Current	72.3A
Peak Apparent Power (10s, off-grid, 3Φ)	90,000VA
Max. Grid Passthrough Current (10min)	200A
Continuous Grid Passthrough Current	180A
Power Factor Output Range	+/- 0.8 adjustable
Backup Transfer Time	Up to 15ms
CEC Efficiency	96.5%
Max Efficiency	97.5%
Design (DC to AC)	Transformerless DC
Stackable	Up to 10 in parallel
Battery Input Data (DC)	
Supported Battery Chemistry	Lithium-ion
No. of Battery Inputs	2
Battery Input Terminal Rating	50A
Nominal DC Voltage	≥ 600V
Operating Voltage Range	160 - 700V
Battery Capacity Range	50 — 9900Ah
Max. Battery Charge / Discharge Current	100A (50A per input)
Charge Controller Type	CC/CV - BMS Controlled
Grid to Battery Charging Efficiency	96.0%
Automatic Generator Start (AGS)	2 Wire Start - Integrated
BMS Communication ³	CAN (Controller Area Network)
General Data	
Dimensions (H x W x D)	894 x 528 x 295 mm (35.2 x 20.8 x 11.6 in)
Weight	80 Kg / 176 lb.
Enclosure	IP65 / NEMA 3R
Operating Temperature	-40 – 60°C, >45°C Derating
Operating Altitude ⁴	2000 m (6561 ft)
Noise Level @ 1m	< 30 dB @ 25°C (77°F)
Idle Consumption - No Load	60W
Communication and Monitoring	Wi-Fi & LAN Hardware Included
Warranty	10 Years
Category	
Certifications and Listings (Grid Support Interactive Inverter)	UL 1741-2021 (UL1741SB), CSA C22.2 No 107.1-16, IEEE 1547-2018 & 1547a-2020 & 1547.1-2020 (SRD V2.0), UL 1741 CRD-PCS, UL1699B, CEC, SGIP, CSIP
PV DC Disconnect Switch — NEC 240.15	Integrated
Ground Fault Detection — NEC 690.5	Integrated
PV Rapid Shutdown Control — NEC 690.12	Integrated
PV Arc Fault Detection — NEC 690.11	Integrated
PV Input Lightning Protection	Integrated
PV String Input Reverse Polarity Protection	Integrated
Surge Protection	DC Type II / AC Type III

¹ See Installation Guide for details on sizing array strings. Highest input voltage is based on the open-circuit voltage of the array at minimum design temperature

² Does not support corner grounded delta, high leg delta, or 240V delta systems. Consult installation manual or solark.com for details..

³ Active BMS communication is required for all lithium batteries. See solark.com for list of compatible battery partners.

⁴ Derating occurs above 2000m (6561 ft).

Sol-Ark reserves the right to modify specifications at any time, and without prior notice. See sol-ark.com for the latest information.

1.3 Connection Requirements

AC/DC Connection Requirements



All wire runs should be sized to be at or below a 2.5% voltage drop at full load. Equipment wire sizing must comply with the NEC or local electrical code.

Copper wire is recommended; if you use aluminum, consult the NEC table to calculate the capacity required.

Port	Max. Terminal Rating	Temperature Rating	Terminal Wiring Size Range (Min/Max)
GRID	200Aac	105C	2AWG – 4/0 AWG
LOAD	200Aac	105C	2AWG – 4/0 AWG
GEN	200Aac	105C	2AWG – 4/0 AWG
MPPT	55Aisc	105C	12 – 10 AWG
Battery Port A	50Adc	105C	6 – 4 AWG
Battery Port B	50Adc	105C	6 – 4 AWG

Sensors and Communications Requirements

Component	Wire Size Range	Max Distance
CT Sensor	16 - 22 AWG	0' – 10' [3 m]: 16 AWG included 10' – 50' [15.3 m]: 14AWG twisted pair extension
Communications	16 – 22 AWG	0' – 100' [30 m]: 24 AWG 100' – 400' [120 m]: 23 AWG
RJ45 Parallel Communication	CAT 5E or better	0' – 7' [2.1 m]: Included 7' – 20' [6m]: Extendable

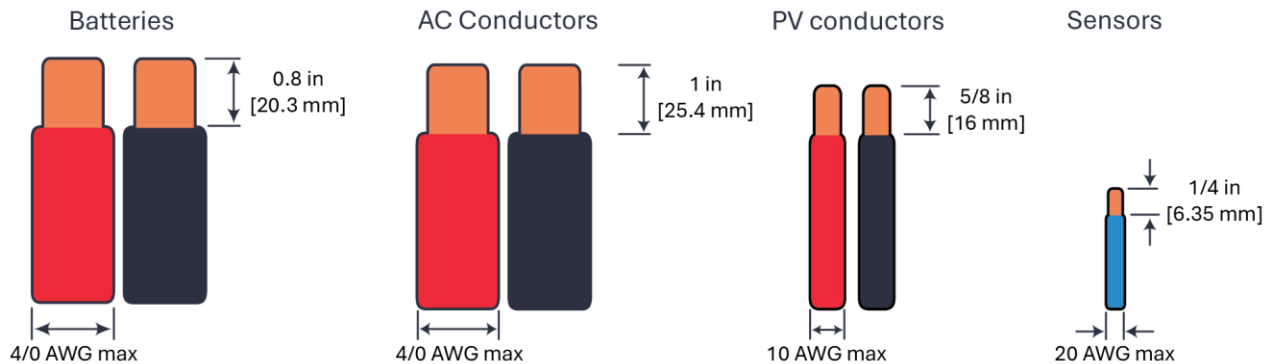

CT Sensors (Included)

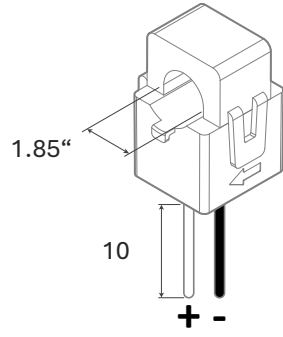

2. Installation

Backup Circuits

A. The **LOAD** connected service panel is called the **Essential Loads Panel**.

You must keep the Essential Loads Panel within the limitations of the unit:

- Three phase power in a Wye configuration is calculated as $\rightarrow \text{Real Power (W)} = \sqrt{3} \times V_L \times I_L \times \text{PF}$
Assuming a unity power factor (PF=1), the maximum power levels for each condition are:
 - Grid Tie Pass Through $\rightarrow 149.6\text{kW cont.} = 1.73 \times 480\text{V} \times 180\text{A} \times 1.0$
 - Off-Grid $\rightarrow 60.1\text{kW cont. (batteries or PV)} = 1.73 \times 480\text{V} \times 72.3\text{A} \times 1.0$

B. Verify that any individual load circuit power or the aggregate rating of the whole panel does not exceed the limits above.

Single System Install

A. For Partial Home Backup

To provide backup power to only essential loads, connect the utility grid to the Sol-Ark inverter's **GRID** terminal. You can make this connection on either the supply side (before your main service panel) or the load side (after your main service panel). With the Sol-Ark's Power Control System (PCS), the system can be configured to provide zero-export control.

- If connecting the inverter using a supply side connection, you must install an external, service-rated disconnect switch between the **GRID** connection and the Sol-Ark. Make sure to size this disconnect according to local electrical codes.
- Connect the Sol-Ark's **LOAD** output to your Essential Loads Panel. Consult local electrical codes to select the correct wire gauge for this connection.

B. For Whole Home Backup

To provide backup power to your entire home with the Sol-Ark acting as the main transfer switch, connect the utility grid's main feed directly to the Sol-Ark inverter's **GRID** terminal.

- You **must** install an external, service-rated disconnect switch between the **GRID** connection and the Sol-Ark. Make sure to size this disconnect according to local electrical codes.
- Connect the Sol-Ark's **LOAD** output to your **Main Service Panel**. Consult local electrical codes to select the correct wire gauge for this connection.

It's possible to connect a generator, or an AC coupled source such as grid-tie string or micro inverters, to the **GEN** terminal of the inverter. Only one AC source can be connected to the **GEN** terminal at a time.

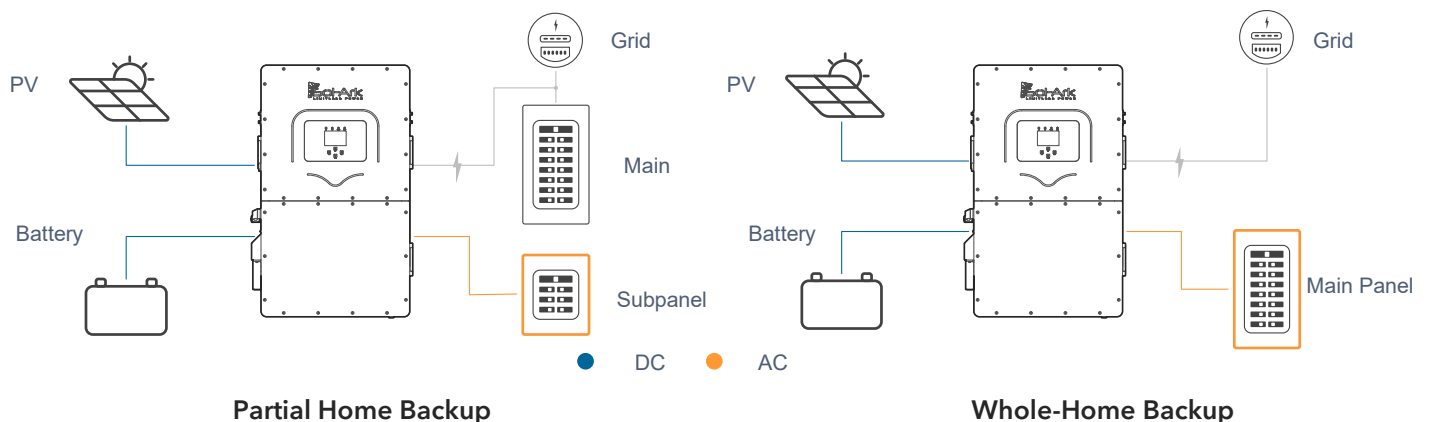

2.1 Mounting the Sol-Ark

Considering the dimensions of the inverter, find a suitable location for the system. There must be at least 6 in [15 cm] of vertical clearance and 2 in [5 cm] of side clearance for proper heat dissipation.

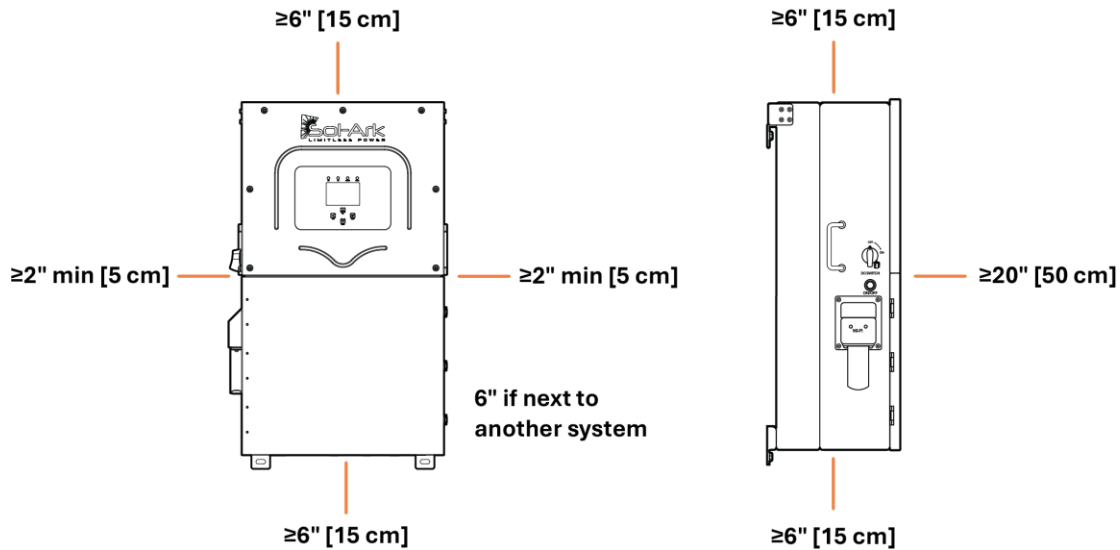

Figure 1: Inverter Clearances Overview



NOTE: Inverter has a Maximum Heat Dissipation of 2,100W or 7,165BTU/hour

1. Under certain conditions, the National Electrical Code® specifies greater clearances. Be sure to adhere to the clearances listed in the National Electrical Code®, paragraph 110.26 and Canadian Electrical Code® CSA C22.1.
2. The Sol-Ark 60K-3P-480V is a NEMA 3R - IP65 enclosure rated for outdoor installation, but it can also be installed indoors.
3. Use screws or anchors suitable for the support surface and capable of supporting the weight of the inverter (230 lb / 105kg).
 - a. For Concrete or Masonry Mounting: Use a minimum of four M12x60mm expanding anchors (included).
 - b. For Wood Frame Mounting: Use a minimum of four ½-in lag screws with flat washers (not included), making sure to anchor into at least 2 framing members.
 - c. For Metal Framing Mounting: Use a minimum of four ¼-in self-tapping metal screws with flat washers (not included).
 - If you need a different anchorage, calculate the number of anchor points needed to properly hold the weight of the equipment.
 - Secure the inverter to the French Cleat with six of the provided M4x12mm socket head screws.

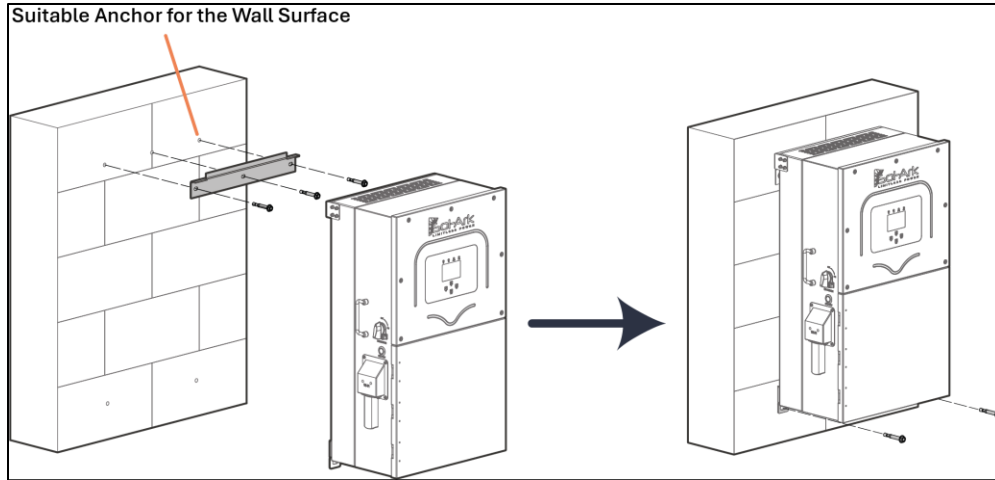

Figure 2: Inverter Mounting Diagram

⚠ Damage to the LCD Screen due to direct sunlight exposure will not be covered by warranty.

4. Mount the inverter in the optimal orientation as shown below.
5. Remove the film cover from the LCD screen.

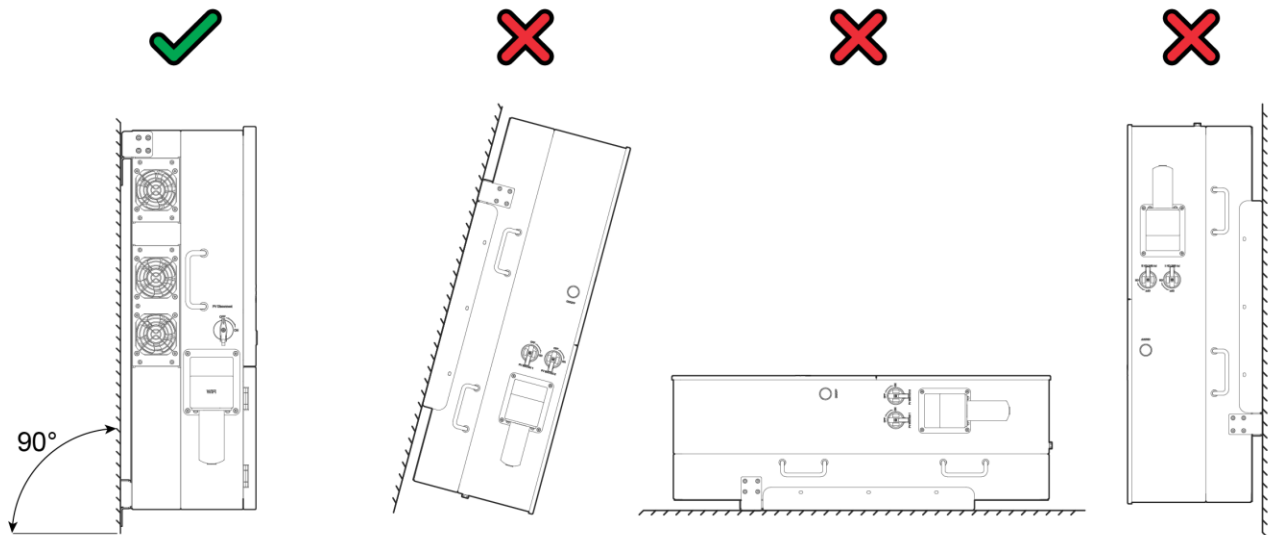

Figure 3: Inverter Mounting Orientation

Installing the LCD Sunshade (outside installations only)

If the Sol-Ark inverter is installed outside, be sure to attach the LCD Sunshade. This will help prevent screen damage from UV exposure.

Peel off the plastic film from the inverter's display surface, if it's not already removed.

1. Make sure the surface is clean and dry before installation.
2. Assemble the sun-shade flap:
 - a. Insert the flap's hinge pins into the hinge slots on the base plate.
 - b. Verify that the flap opens and closes smoothly.
3. Attach the base plate:
 - a. Peel the backing from the double-sided adhesive tape.
 - b. Align the base plate with the display area just above the LED lights for DC, AC, Normal, and Alarm.
 - c. The adhesive is permanent, so confirm the alignment before applying pressure.
 - d. Press firmly to secure the LCD Sunshade.

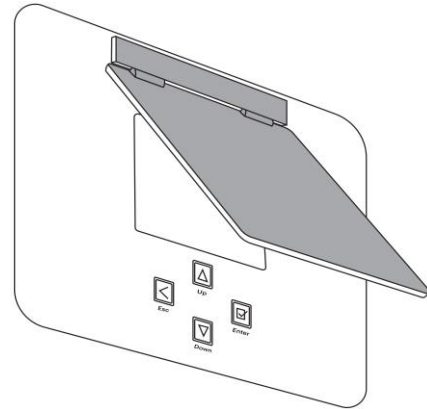

The flap should cover the LED lights, LCD, and the blister-type buttons when properly installed.

 Damage to the LCD Screen due to direct sunlight exposure will not be covered by warranty.

Need to purchase an LCD Sunshade?

LCD Sunshades were included with Sol-Ark inverters starting on May 4, 2026. If you have an outdoor installation and did not receive an LCD Sunshade, you can purchase one by going to the [Sol-Ark Online Store](#).

2.2 Integrating Batteries

⚠ Sol-Ark 60K-3P-480V must be OFF while you connect the batteries.

Be sure that the external battery disconnect is **OFF** or arcing may occur. If your battery bank does not have a built-in disconnect, maintain the necessary safety measures when handling the connections.

! The 60K-3P-480V reaches a max battery charge/discharge of **50A** per terminal for a total max of **100A** if using both sets of battery terminals. If only one set of terminals is used, the battery charge/discharge will be limited to **50A**.

⚠ Sol-Ark 60K-3P-480V is a **HIGH VOLTAGE BATTERY** system. You **MUST NOT** exceed **800V_{DC}** as shown below. The HV battery must stay within the **160V_{DC} - 700V_{DC}** operating voltage range. **DO NOT** connect to any battery whose max voltage that exceeds this limit.

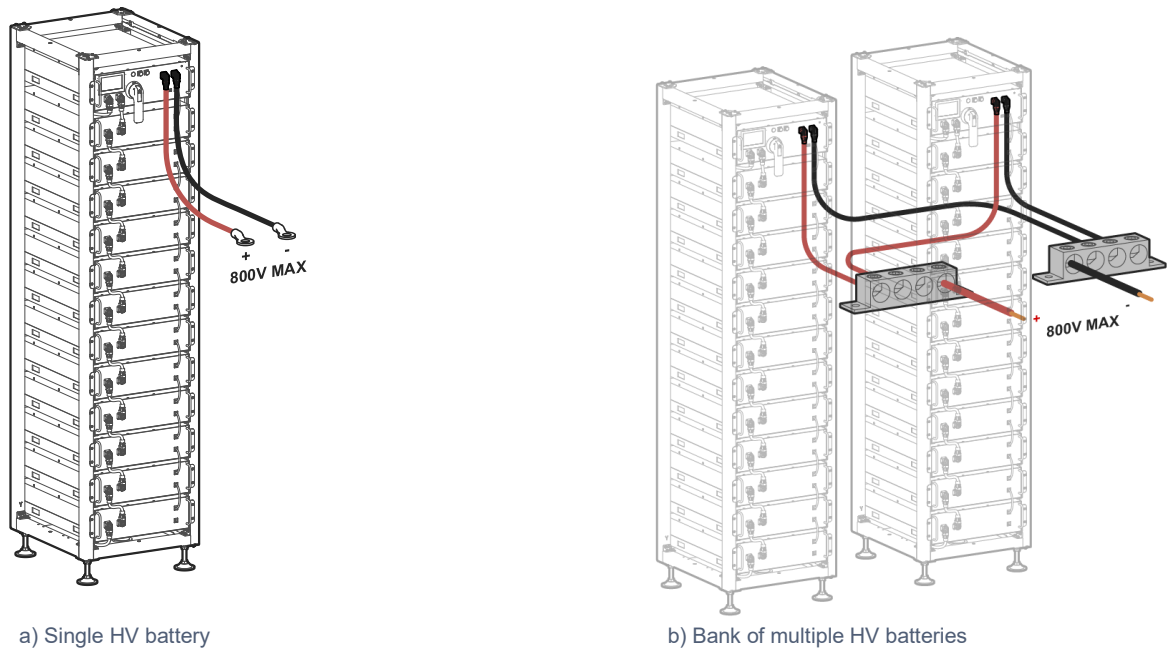
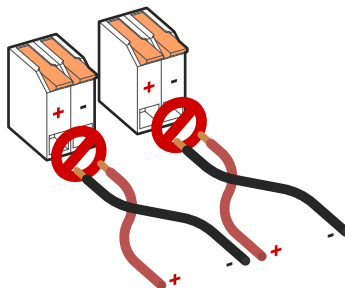

Figure 4: Battery Wiring Output

The Sol-Ark inverter has two input battery terminals for single or dual battery connections. To wire a battery to the inverter, lift the actuation levers and insert the **6-4 AWG** battery conductor fully into the terminal. **DO NOT** force open the battery actuation levers more than **90°**.



DANGER: Reverse Polarity
DO NOT reverse the battery input wires, the system will be damaged, and the warranty voided.

Multi-Terminal Installation

The two battery input terminals of the 60K-3P-480V can be configured for parallel battery stacks in settings screens. If the charge/discharge rate $>50A$ is needed, the battery must be connected to both input terminals. If connecting more than one battery to a single inverter input terminal, you must use an external busbar or combiner to combine batteries positive and negative outputs before connecting to the inverter terminals.

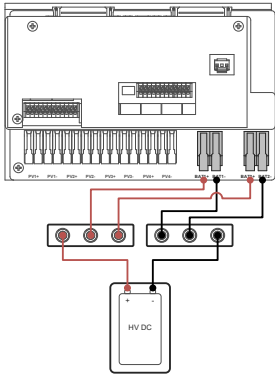

a. Single battery

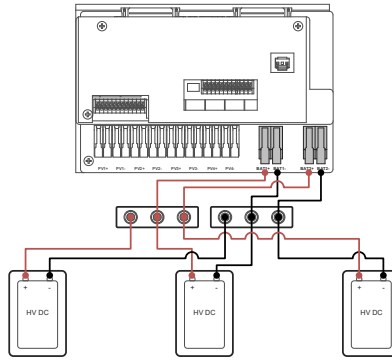

b. Parallel battery bank

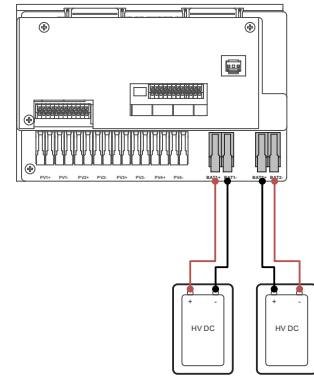

c. Dual battery bank



Note: If a single battery is capable of charge/discharge currents above 50A, connect the battery to both input terminals. Otherwise, the charge and discharge rate will be limited to 50A max. Only connect batteries of the same model to the terminals

Paralleled Battery Installations



Note: Multi-Inverter Installations

Contact Sol-Ark Technical Support at +1 (972) 575-8875, ext. 2 for help with commissioning multiple paralleled inverters.

- **ALL** systems **MUST** be connected to their own battery bank, and the battery banks must be the same size.
- **DO NOT** parallel batteries between inverters.

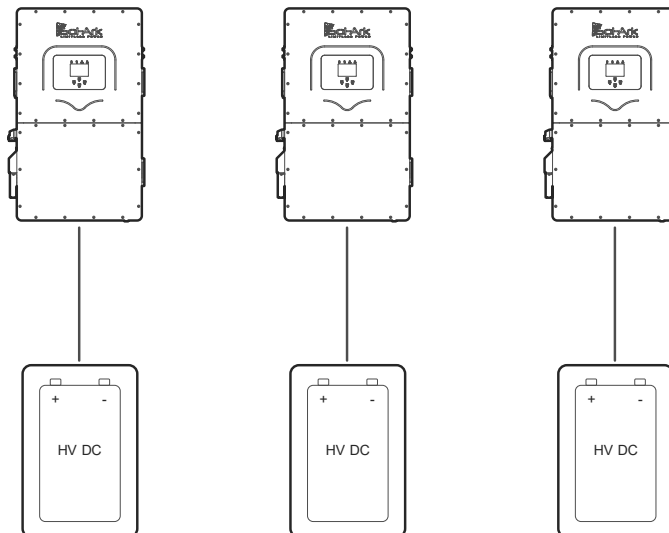

Figure 5: Inverter to Battery Ratio Diagram

2.3 Battery Communications

The Sol-Ark 60K-3P-480V inverter can establish closed-loop battery communication through one or two separate RJ-45 ports labeled **BMS1** and **BMS2**. Communication with battery BMS depends on the wiring of the battery bank and the wiring to the Sol-Ark inverter. The following two methods show how communications can be established:

Single Battery Bank Communication

Configure and wire the HV batteries so that there is one battery bank with a single communication source. Closed-loop communication is established by connecting the com cable to the **BMS1** port of the Sol-Ark inverter.

! **Parallel Bat1&Bat2** setting on the Batt setup menu **MUST** be enabled and batteries must be connected in parallel on the DC side. See “Multi-Terminal Installation” on page 12 for detailed wiring of multi-terminal, single battery bank installation.

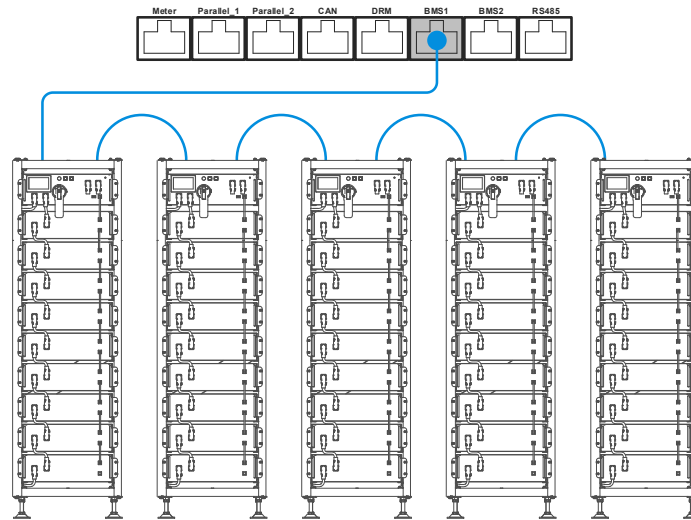

Figure 6: Single battery bank communication

Parallel bat1&bat2: Must be checked when using both battery inputs for the same battery bank. When enabled, the inverter will expect a single battery communication source.

Separate Battery Banks Communications

Configure and wire the HV batteries so that there are two battery banks, each with their separate communication source. Establish closed-loop communications by connecting each communication cable to a BMS port of the Sol-Ark (**BMS1** and **BMS2**).

! **Parallel Bat1&Bat2** setting on the Batt setup menu **SHOULD NOT** be enabled, the dual battery bank wiring configuration shown earlier **MUST** be carried out. See “Multi-Terminal Installation” on page 12 for detailed wiring of parallel battery bank and dual battery bank installation.



Figure 7: Multi-Battery Bank Communications

2.4 Connecting Solar PV to the Inverter



60K-3P-480V has 4 independent MPPTs that support up to 2 PV strings each. The MPPTs can handle a maximum V_{oc} of 1,000V and an I_{sc} of 55A but will self-limit and operate at I_{mp} of 36A max.

- A. Max DC solar input = 78 kW ($\pm 5\%$) | Max input power per MPPT = 19.5 kW | Max recommended input voltage per MPPT = 850 V_{oc} | Max input current per MPPT = 36A (self-limiting).
- B. Design for an input current of 36A per MPPT. The inverter will self-limit beyond 36A. If I_{sc} exceeds 55A, damage will occur.
- C. **PV Source Circuit max voltage of 1,000 V_{oc}**
- D. **Damage can occur with PV strings whose open-circuit voltage exceeds 1,000 V_{oc}**
- E. Strings in parallel on the same MPPT must have the same designed open-circuit voltage (V_{oc}); otherwise, the system will be limited to the lowest string voltage.
 - PV1 A/B must have the same V_{oc} .
 - If the solar panels are oriented in different directions and connected in the same MPPT, there will be a loss in PV efficiency.
- F. According to NEC Art 690.43, exposed non-current-carrying metal parts of PV module frames, electrical equipment, and conductor enclosures of PV systems shall be connected to an equipment grounding conductor. All grounding conductors and grounding electrodes should be installed according to NEC Art 690.47 or as required by the AHJ.
- G. For ground mounted arrays, Sol-Ark recommends installing an auxiliary grounding electrode placed near the array to ensure optimal earth-to-ground resistance of the grounding system. This auxiliary electrode would need to follow the requirements of NEC Art. 250.54.
- H. Connect the solar panel strings using either of the following configurations:

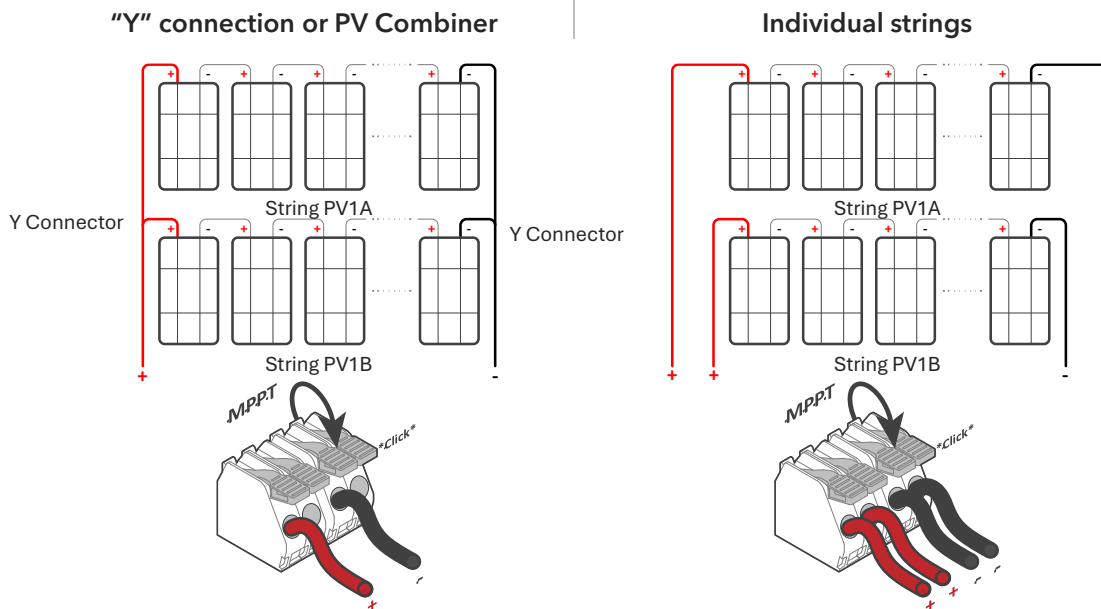

AC Coupling

The Sol-Ark 60K-3P-480V supports the addition of grid-tied solar inverters, this allows the systems total solar power input to be expanded by coupling 3 Φ micro or string inverters into the **GEN** terminals of the inverter.

An entirely AC-coupled solar system is not recommended as power control and monitoring is limited but is supported. Having DC-coupled modules, or a combination of DC-coupled modules and AC-coupled inverters is always preferred. AC-coupled inverters used in this application need to be either UL 1741SA or SB certified. This certification confirms the inverters' ability to disconnect from the grid based on frequency and ensures that the Sol-Ark will safely be able to frequency shift to control the AC coupled production.

In off-grid systems or during grid-forming operation, the 60K-3P-480V uses frequency shifting to curtail and shutdown AC-coupled inverters when the battery is full, allowing AC-coupled solar to produce power in an outage scenario. When the 60K-3P-480V is connected to the grid any AC-coupled inverters connected will always sell all excess solar power back to the grid. Selecting **Limited to Load** will NOT limit production when AC coupled.

 Maximum allowed AC coupling input: 60,000WAC

AC Coupling on the **GRID** Side

Installing AC coupled inverters upstream of the **GRID** port of the 60K-3P-480V, such as with a load or supply side connection, is supported for grid connected systems but has some notable limitations when using the inverter for backup or grid-forming mode:

- Does NOT allow the usage of grid-tied inverter production during grid outages to charge batteries or power loads.
- Does NOT allow monitoring of PV production in inverter and MySolArk monitoring.

AC Coupling on the **GEN** Terminal

AC Coupling via the GEN Terminal is the preferred method for integrating AC-coupled solar on the 60K-3P-480V. This method offers several key advantages:

- Allows the usage of grid-tied inverter production during grid outages.
- Allows the integration of grid-tie inverters in off-grid systems.

Using the GEN terminal also allows for comprehensive monitoring of solar production, giving users valuable insights into the system's performance. See "AC Coupling Settings (for AC Coupled Input)" on page 40 for details on programming the 60K-3P-480V for this mode of operation.

*Dark Start with AC Coupling on **GEN***

If the inverter is running off-grid and reaches battery shutdown, the inverter will close the **GEN** relay for 10 minutes to try to import AC coupled power. This process will repeat three times per day, every 2.5 hours. If the three attempts fail, the timer will restart the next day at 8:10 AM and repeat the process.

 For dark start to succeed, AC coupled power must exceed the load profile so it can charge the batteries.

AC Coupling on the **LOAD** Terminal



 **NOTICE:** Sol-Ark does not support AC-coupling on the LOAD terminal with the 60K-3P-480V.

2.5 Integrating a Generator

Generators Smaller than 149kW → On **GEN** Input



- Supports ONLY three-phase 480Vac generators
- 200A rated **GEN** terminal.  180A continuous
- A THD (Total Harmonic Distortion) of less than 15% is required for stable operation

Generators Greater than 149kW → On **GRID** Input

- Supports ONLY three-phase 480Vac generators.
- Optimal way to integrate generators for Off-Grid or Grid-Tied systems with automatic or manual transfer switches.
-  Programming **GEN Connect to Grid Input** is required:  → **Limitter** → **Other** → **GEN Connect to Grid Input**.
-  **DO NOT** use **Grid Sell** when generator is connected to the GRID input, can cause potential damage the generator. Installation of CT sensors on generator lines is only required if “**Peak Shaving**” is intended to be used.

Improve the Generator and Sol-Ark Compatibility

Navigate to  → **Grid Setup** → **Grid Selection** → **Grid Mode** and program the following values to improve the Sol-Ark and generator compatibility and operating range to avoid frequent disconnections.

1. Change the grid mode to General Standard:  → **Grid Setup** → **Grid Selection** → **Grid Mode**
 - a. Tap and use the navigation arrows to cycle through the different grid modes; then choose **General Standard**
2. Increase the frequency range of operation:  → **Grid Setup** → **Connect** → **Reconnect**
 - a. Increase **Grid Hz High to 65Hz**
 - b. Decrease **Grid Hz Low to 55Hz**
 - c. Make the same changes for the **Normal Connect** settings
3. Increase the voltage range of operation:
 - a. Increase **Grid Volt High to 528V**
 - b. Decrease **Grid Volt Low to 432V**
 - c. Make the same changes for the **Normal Connect** settings



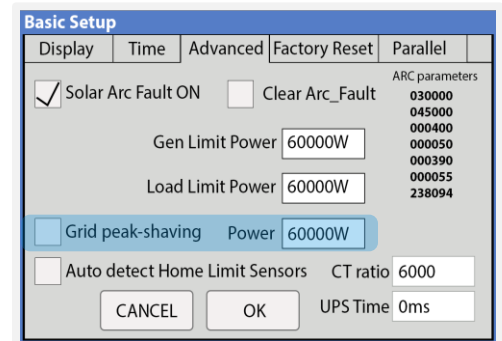

2.6 Grid Peak Shaving

1.  To use Peak-Shaving on a generator, the equipment **MUST** be connected to the **GRID** terminal of the inverter.
2. Peak-Shaving helps reduce grid consumption during peak demand by utilizing battery backup power. It can also be used to prevent generator overload above a specified power threshold.
3. Install the CT sensors on grid / generator lines L1, L2, L3. The arrows on the CTs **MUST** point toward the inverter.
4. The Sol-Ark supplies power from the batteries whenever the “**Power**” threshold is met.
5. This mode will automatically adjust the **Grid Charge** amperage (A) to avoid generator overloads during battery charging.
6. Grid Peak-Shaving will automatically enable **Time of Use** and **MUST** be configured.



Grid peak-shaving settings

2.7 Automatic Generator Start

1. **Gen Charge** is used when the generator is connected to the **GEN** terminal.
 - a. **Start V or Start %** is the set-point/condition that must be fulfilled to automatically start the generator.
 - b. To charge from the **GEN** source, **Gen Charge** must be enabled.
 - c.  Batteries will charge from a generator until the battery bank accepts 5% of its programmed capacity in Amperes (A). This is equivalent to around 95% of the state of charge (SOC).
2. **Grid Charge** is used to charge the battery from the **GRID** source (grid or a generator).
 - a. **Start V or Start %** is the set-point/condition that must be fulfilled to start the battery charge from the **GRID** source. This will auto-start a generator as well.
 - b. To charge the battery from the **GRID** source, you must select  **Battery Setup > Charge >** **Grid Charge**
 -  From utility grid: the batteries will be charged to 100% SOC.
 -  From generator: the batteries will charge until the battery bank accepts 5% of its rated capacity in Amperes (A). This is equivalent to around 95% SOC.

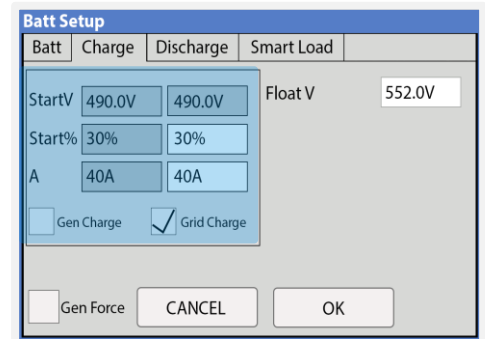

Generator and grid charge settings



NOTE: If **Time of Use** (TOU) is enabled, you must designate a time to charge from that GRID or GEN source. Select **Charge** on the desired time intervals; otherwise, the generator will not start automatically even if the **Start V** or **Start %** condition has been met.

Gen Charge / Grid Charge “A”

A is how many amps (DC) are supplied to the battery from the **GRID** or **GEN** source. Adjusting and limiting the **Gen** or **Grid A** value will ensure that small generators are not overloaded when charging the battery bank. If connecting more than one HV battery in parallel to the Sol-Ark inverter, divide the **Gen** or **Grid A** value by the **number of batteries** to estimate the current (A) flowing to each HV battery.

2.8 Integrating Sensors and Accessories

Overview of Inverter Pinouts

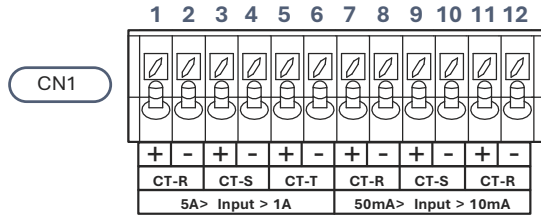

Inverter Terminal Blocks

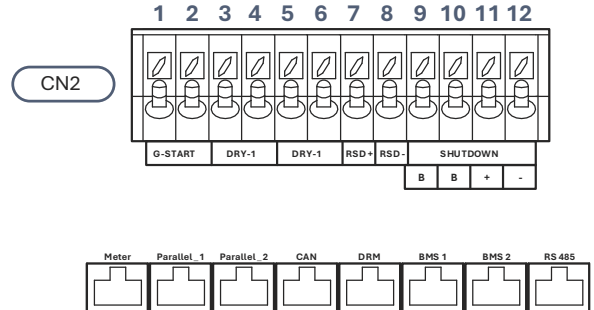

Sensor Pinout

Sensor Pinouts are located in Sol-Ark user area.

CN1

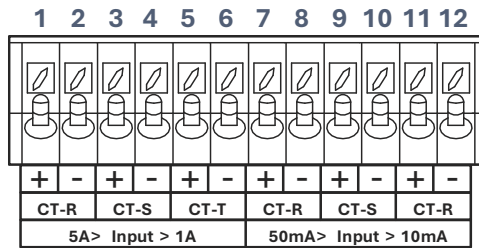

Figure 8: CT Sensor Input Pinout

Max. 5A Secondary CTs ONLY:

- (1,2) 5A to 1A Input - CT-R: Current transformer (L1). **Polarity sensitive.**
- (3,4) 5A to 1A Input - CT-S: Current transformer (L2). **Polarity sensitive.**
- (5,6) 5A to 1A Input - CT-T: Current transformer (L3). **Polarity sensitive.**

Max. 50mA Secondary CTs ONLY:

- (7,8) 10mA to 50mA Input - CT-R: Current transformer (L1). **Polarity sensitive.**
- (9,10) 10mA to 50mA Input - CT-S: Current transformer (L2). **Polarity sensitive.**
- (11,12) 10mA to 50mA Input - CT-T: Current transformer. (L3). **Polarity sensitive.**

CN2

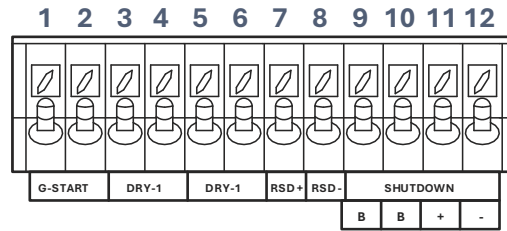

Figure 9: CN2 Pinout

- (1,2) **G-Start**: Normally Open (NO) relay for generator two-wire start
- (⚠️) **12V, 100mA max**
- (3,4) **Dry-1** and (5,6) **Dry-2**: Reserved
- (7,8) **RSD+/-**: Reserved, DO NOT CONNECT ANY RSD TRANSMITTER
- (9,10) **Emergency Stop Button**: Normally Open (NO) dry contact for emergency stop button
- (11, 12) **+/-** : Reserved, not used at this time.

Communication Ports

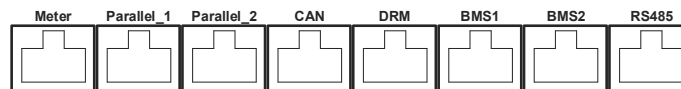

Figure 10: Communication Ports

- **Meter**: For external Revenue Grade energy meter communication.
- **Parallel_1 & Parallel_2**: Inverter parallel communications ports 1 and 2.
- **CAN**: Reserved.
- **DRM**: Reserved.
- **RS-485**: RS-485 port
- **BMS1 & BMS2**: BMS ports 1 and 2 for battery communications

CAN & RS485 Ports

- CAN port data is in a proprietary format. Sol-Ark currently does not support third-party usage.
- The RS485/RTU port utilizes the MODBUS protocol; data is in a proprietary format. Please contact Sol-Ark to request the MODBUS register map if it's required for your application.

Pin	RS485	CAN
1	B-	B-
2	A+	A+
3	--	--
4	--	CAN High
5	--	CAN Low
6	GND	GND
7	A+	A+
8	B-	B-

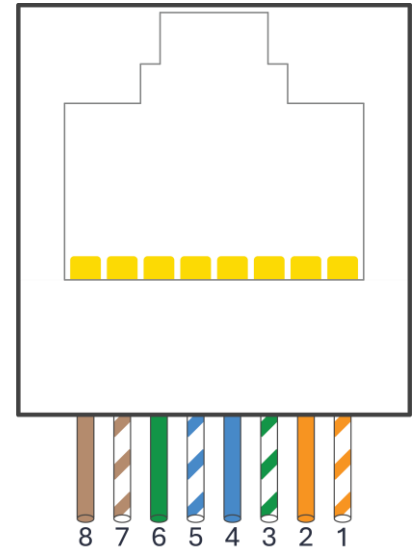

BMS Communication Ports

Pin	BMS1	BMS2
1	--	--
2	--	--
3	--	--
4	CAN High	CAN High
5	CAN Low	CAN Low
6	GND	GND
7	--	--
8	--	--

GEN Start Signal (Two-wire start)

- Gen start relay: CN2, pins 1 & 2.
- The signal comes from a normally open relay that closes when the generator **Start** condition is met.

Wi-Fi / Ethernet Antenna (Dongle)

- Remote monitoring and software updates require an internet connection through the Wi-Fi / Ethernet Gateway (Dongle).
- Supports with 2.4GHz Wi-Fi or Ethernet connections.

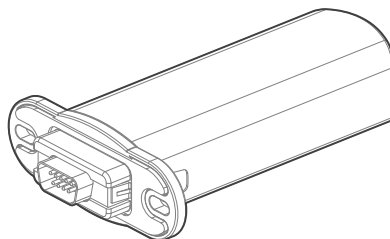

Figure 11: WiFi Gateway

Installing Filter Rings

If your 60K Sol-Ark inverter came with a set of filter rings (toroids), follow these steps to install them on the battery conductors. The filter rings include:

- **2 small white filter rings** for BMS1 and BMS2 communications cable (outside diameter 33mm)
- **1 large black filter ring** for AC wires (outside diameter 92mm, inside diameter 55mm).

Make sure that both (+) and (-) wires pass through both filter rings simultaneously. When there are 4 wires, all conductors must go through the filter rings as described below.

Step 1: Install small white filter rings on **BMS1** and **BMS2**

- Thread the end of the BMS communication cables through one filter ring, then wrap the wires around the ring four times. Place the filter ring near the wiring terminals.
- Repeat this for the other BMS communication cable if you are using two BMS ports.

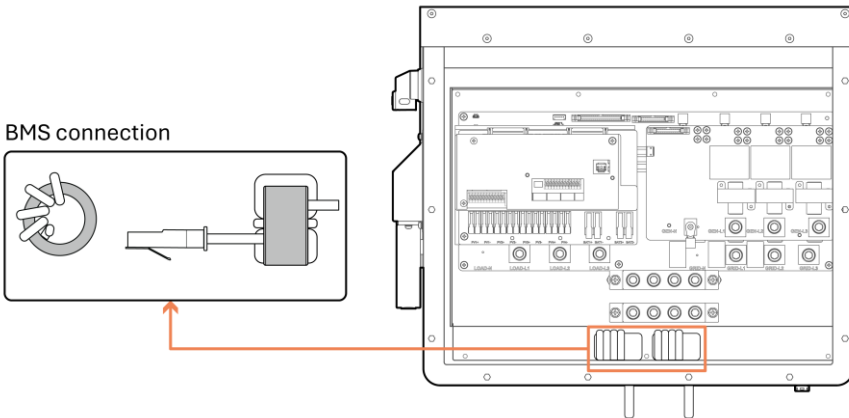

Step 2: Install large black filter ring on **GRID** terminals

Thread the wires through the filter ring and THEN connect the wires to the **GRID** port.

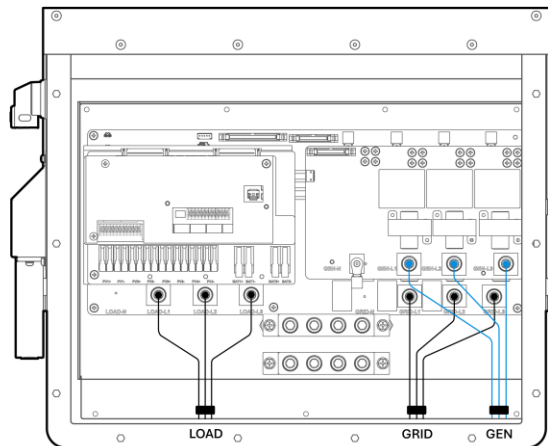

2.9 Connecting Current Transformers (CT Sensors)

The CT sensors (or limit sensors) enhance system capabilities by enabling the use of the system work modes known as **Limited Power to Home (Meter Zero)** and **Grid Peak-Shaving**. The CTs will measure and calculate total load demand which the Sol-Ark 60K-3P-480V will then use to accurately supply and offset all existing loads (Meter Zero).

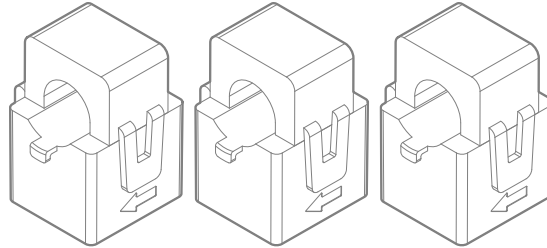

Figure 12: CT Sensors

2.9.1 Installing CT Sensors



DANGER: RISK OF ELECTRIC SHOCK

Before installing CT sensors around current-carrying conductors, you **MUST**:

1. Connect the CT outputs to the designated inverter input terminals, OR
2. Short the CT output wires using a CT shorting block

This step is crucial to prevent the generation of dangerously high voltages in the CT secondary winding when this circuit is open and current is flowing through the primary.

1. Install sensors on incoming electrical service wires (L1, L2, L3).

The marked arrows on the CT sensors must point **toward** the inverter.

2. To ensure proper fit, check incoming wire diameters (grid or generator). If the sensors are too small for the service needed, larger CTs can be purchased.

“Limited Power to Home” (Meter Zero) and **“Grid Peak Shaving”** require CT sensors.

- See “3.5 Limiter” on page 41 for more information about the different work modes.
- See “7. Wiring Diagrams” starting on page 63 for more information on CT installation.

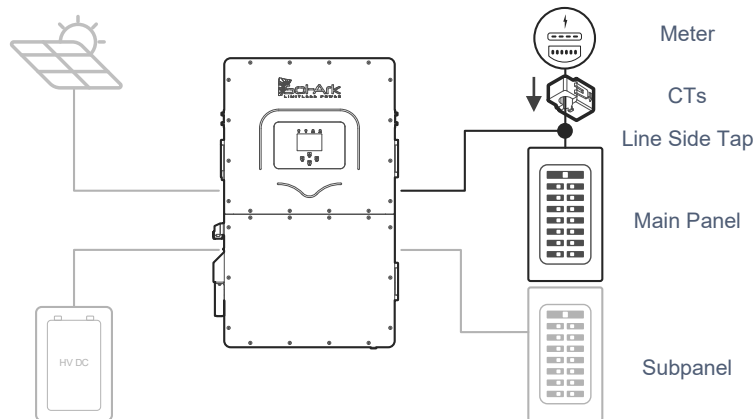

Figure 13: Overview of CT Placement

CT Sensor Size

1. The 60K-3P-480V inverter includes three **300A** CT sensors with a 1.85x2” (47x52mm) opening.
2. The inverter should be programmed to use a ratio of **6000:1** if using the included 300A CT’s.
3. For sites with services larger than 300A, see “2.9.2 Selecting Current Transformers for Larger Services” on page 25.

 Unless authorized, **DO NOT** change CT Ratio or warranty will be voided.

Wiring the CT sensors

1. Connect CT1 of line L1 to pins 1+ (white) and 2- (black) of CN1 pin board as shown in the figure below.
2. Connect CT2 of line L2 to pins 3+ (white) and 4- (black) of CN1 pin board.
3. Connect CT3 of line L3 to pins 5+ (white) and 6- (black) of CN1 pin board.
4. Keep the wires twisted throughout the run and only separate 1in (25mm) when making the termination at the inverter.
5. If the wires need to be extended, use a minimum of 16AWG twisted pair shielded cable to make the extension.
 - o The maximum CT extension length is 50ft using 14AWG twisted pair cable. For longer runs, contact Sol-Ark for design assistance.

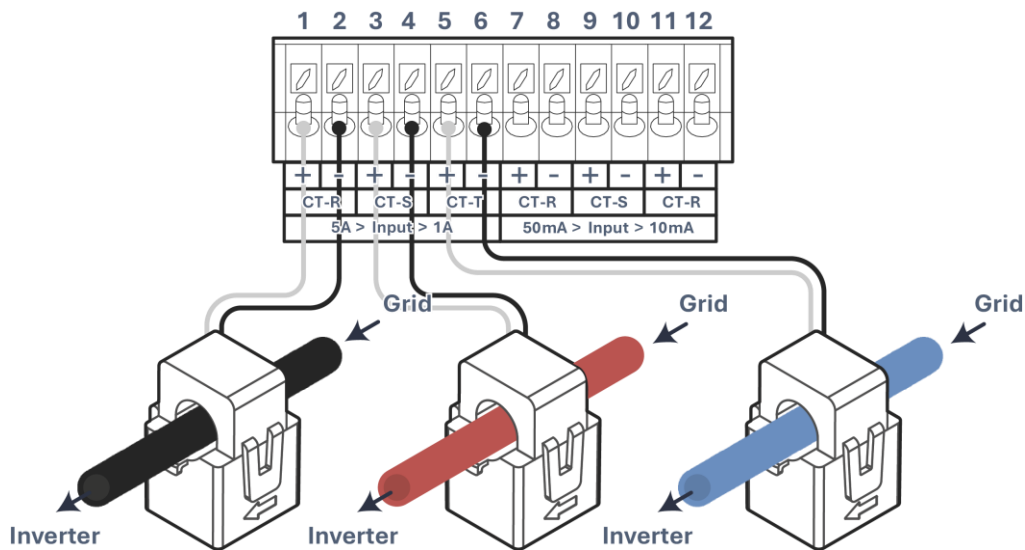

Figure 14: CT to Inverter Wiring

CT Sensors with Parallel Inverters

Only one set of CT sensors need to be wired to the designated “Master” inverter.

 CT sensors are required for multi-inverter systems.

2.9.2 Selecting Current Transformers for Larger Services

If the included CTs are not suitable for the installation service, larger CTs can be purchased separately.

When selecting the CT, size the primary rating as close to the service size of the panel as practical. This ensures accurate measurements and proper system operation.

For example, for a site with a 400A service panel, choose a CT with a 400A primary rating or the next available higher rating. Selecting a CT with a primary rating significantly higher than the service size may result in reduced accuracy for lower current measurements.

The following devices have been tested thoroughly to comply with Power Control System (PCS) operation per UL1741 CRD with the 60K-3P-480V inverter:

Manufacturer	Model	Current Rating	Inverter CT Ratio	Window Size	Datasheet
AccuEnergy	AcuCT-3135R	600A:5A 800A:5A 1200A:5A	12000:1 16000:1 24000:1	80.0mm x 90.0mm (3.10" x 3.50")	Brochure
AccuEnergy	AcuCT-4161R	600A: 5A 800A:5A 1200A:5A	12000:1 16000:1 24000:1	105.0mm x 155.0mm (4.10" x 6.10")	Brochure



NOTE: These CTs are compatible with Sol-Ark HV inverters only. Do not use with Sol-Ark LV inverters.

Programming CT Ratios

To program the inverter with the correct CT ratio, follow these steps.

1. Go to  → **Basic Setup** → **Advanced** on the inverter screen:

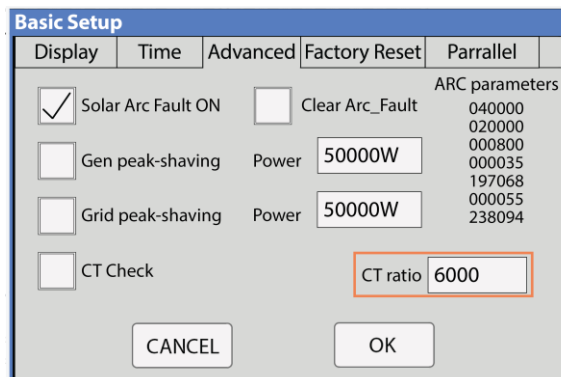

Figure 15: Settings Screen for modifying CT Ratio

2. Calculate the correct CT ratio:
 - a. Divide the primary side current by the secondary side output current
 - b. Multiply the result by 100
3. Enter the number into the **CT Ratio** setting on the inverter.

Example: 800A primary with a 5A secondary output, $800A / 5A = 160$ or 16,000 ratio on the inverter.



2.9.3 Configuring Automatic CT Limit Sensors

This function **REQUIRES** batteries to auto-detect and auto-correct CT orientation. AC coupled inverters need to be **OFF** during the detection test. If this test is done with connected AC-coupled systems, a factory reset of the Sol-Ark must be performed.

Install the CT sensor as described above. A battery connection and grid power are required before starting the automatic configuration.

⚙️ → **Basic Setup** → **Advanced** → **Auto detect Home Limit Sensors**

Wait at least 10 to 15 seconds while the inverter performs the test. The inverter will alternate the current distribution in all lines, determining the correct orientation of the sensor.

Operational Notes

- On **Limited power to Home** mode (no Grid Sell), HM values will read close to zero (0). Note that many sensors can have a 1-3 percent error.
- To avoid selling power to the utility, set **Zero Export Power** equal to or greater than 20W.
- Buying power from the grid will display positive (+) HM values, while selling to the grid displays negative (-) HM values

2.10 Emergency Stop and Rapid Shutdown (RSD)

Rapid shutdown is a critical safety feature required by the National Electrical Code (NEC) for solar photovoltaic systems located on buildings. It allows first responders to quickly de-energize the DC and AC conductors of a solar system in an emergency.

The 60K-3P-480V inverter implements rapid shutdown using the emergency stop pins located in the CN2 wiring area. Pins 7/8 are a normally open (NO) contact that will trigger rapid shutdown (RSD) when closed. Closing this contact using an external e-stop button (not included) will disable all power flows from the inverter, including the **LOAD** output when off-grid.

When this same button is wired to the RSD device power supply, it will also trigger module-level shutdown at the solar module, using module-level shutdown or optimizer modules.

Connect an emergency stop button to CN2, (B, B) pins 9 & 10 of the Sol-Ark.

- ⚠ Rapid Shutdown Transmitters placed inside the user area of the Sol-Ark can cause interference.
- ⚠ On parallel inverter installations, the emergency stop button must be wired to the designated “Master” inverter. Unlike the Master, the “slave” inverters won’t lose their 12Vdc power supply (terminals 7,8).



CAUTION: The 12Vdc power supply on Pins 7 & 8 of the 60K-3P-480V is not rated to power Rapid Shutdown Transmitters. DO NOT CONNECT any device to these terminals

Third-party rapid shutdown transmitters should be powered by the 60K-3P-480V through an external power supply connected to the **LOAD** output, as shown in the figure below. Pressing the e-stop button will disconnect all AC outputs, cutting power to the **LOAD** connected service panel. This initiates rapid shutdown.

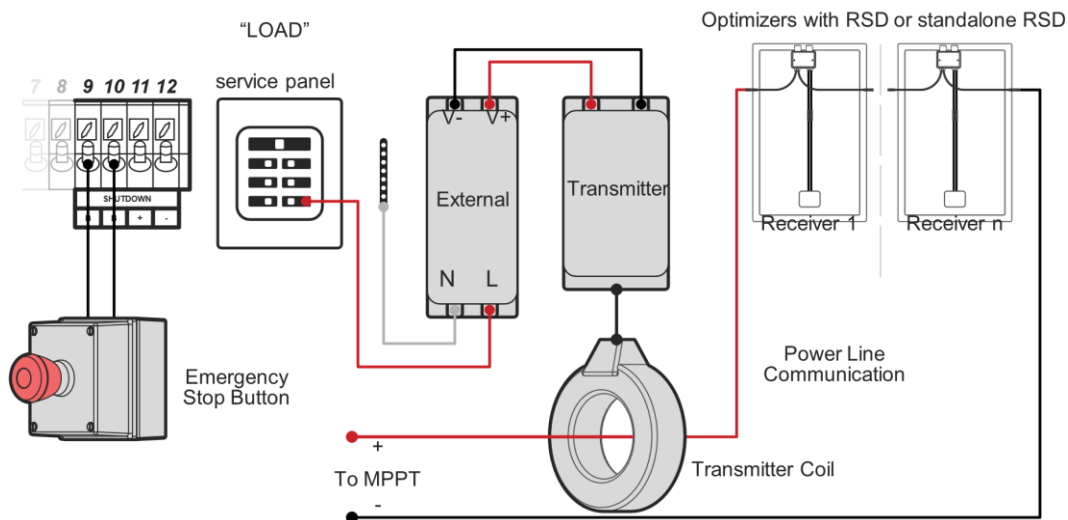

Figure 16: Example Rapid Shutdown Wiring Configuration



Rapid Shutdown Product Recommendations

The following Rapid Shutdown Devices (RSDs) are compatible with the 60K-3P-480 inverter:

- Tigo TS4-A-F
- Tigo TS4-A-2F
- NEP PVG-Guard
- APsmart RSD S-PLC
- APsmart RSD-D

RSDs must be installed according to both manufacturer specifications and local electrical codes. For detailed installation procedures and troubleshooting of Rapid Shutdown Devices, see the device manufacturer's installation manual.

2.11 Electrical System Compatibility

IMPORTANT: Verify electrical system compatibility before installation.

The Sol-Ark 60K-3P-480V supports two standard commercial electrical configurations. Verify your system type before proceeding with installation.

Supported Systems

277/480V 4-wire Wye (Most Common)

- Line-to-neutral: 277V AC
- Line-to-line: 480V AC
- Includes neutral and equipment grounding conductors for unbalanced 277V loads
- Standard for most commercial buildings in North America

480V 3-wire Delta

- Line-to-line: 480V AC (all combinations)
- No neutral conductor required for inverter operation
- Three phase conductors plus equipment grounding conductor
- Found only in older industrial facilities or rural locations
- Requires phase-to-phase fault detection or other NEC approved system for safety
- Consult NEC Article 250.20 or applicable local code for grounding requirements

Unsupported Systems

WARNING: Connecting to incompatible electrical systems will damage the inverter and may void the equipment warranty

- **Corner grounded 3-wire delta** systems
- **High leg delta** (wild Leg/stinger Leg) systems
- **347/600V Wye** systems (most common in Canada)
- Any ungrounded electrical systems



System Verification Procedure

For 277/480V Wye Systems

1. **Measure line-to-neutral voltages:** Should read 277V AC ($\pm 10\%$) on all three phases
2. **Measure line-to-line voltages:** Should read 480V AC ($\pm 10\%$) between all phase combinations
3. **Verify neutral-to-ground bond:** Should measure 0V AC between neutral and equipment ground at main service disconnect

For 480V Delta Systems

1. Measure line-to-line voltages: Should read 480V AC ($\pm 10\%$) between all phase combinations (A-B, B-C, C-A)
2. Check grounding: Verify proper equipment grounding conductor installation

CAUTION: If measurements differ from expected values or if you encounter:

- 208V readings to any conductor
- Unequal line-to-line voltages
- Missing or improper grounding

DO NOT proceed with installation. Consult Sol-Ark support.

Grid Setup Configuration

1. After verifying system compatibility, configure the inverter for your electrical system:
2. Navigate to: Settings (**Gear**) \rightarrow **Grid Setup** \rightarrow **Grid Selection**
3. Select appropriate setting: **LN:277VAC LL:480VAC** for all 480V systems

480V Wye Systems

- Do NOT check **IT system neutral is not GND**

480V Delta Systems ONLY

- Check the check box **IT system neutral is not GND**

2.12 Inverter Startup and Commissioning



NOTE: TURN ON the inverter with at least one of the following power sources:
1. Battery, 2. PV, or 3. Grid/Generator

1. Verify the battery input

- A. ⚠ Voltage of the battery must be between $160V_{DC}$ - $800V_{DC}$.
- B. Turn **ON** battery modules and ensure appropriate voltage on each battery. Verify nominal voltage of battery bank according to the battery installation manual.
- C. Turn **ON** the external battery disconnect. Verify that the voltage at the Sol-Ark terminals is within 2% of the voltage measured at the battery bank output.
- D. ⚠ **DO NOT** reverse polarity. **DO NOT** turn **OFF** battery disconnect if any current is flowing into or out of the battery.

2. Verify the PV input

- A. ⚠ Input voltage must not exceed $1,000V_{DC}$.
- B. Input voltage must be above the startup voltage of $150V_{DC}$.
- C. ⚠ Do not ground PV+ or PV-.
- D. ⚠ Verify polarity in each PV string. Backward polarity will measure $0V_{dc}$ by the Sol-Ark and will cause long term damage.



Figure 17: PV Disconnect Operation

- E. ⓘ PV alone turns LCD screen only. Inverter requires **grid** and/or **batteries** to operate, otherwise an “OFF” message will appear.
- F. PV DC disconnect switches on the side of the inverter turn the PV ON or OFF.

3. Verify the GRID Input

- A. Verify that voltage between Neutral and Ground is $0V_{AC}$.
- B. Verify that voltage between **GRID L1** and **LOAD L1** is $0V$. Do the same for L2 and L3.
- C. Verify the AC voltage on the **GRID** terminals using digital multimeter.

For 277/480V Wye Services

- Measure line (L) to neutral (N) voltages on **GRID** terminals.
- Ensure $277V_{AC}$ on all phases to neutral or ground and $480V_{AC}$ between all phases to each other.

For 480V Delta Services

- Measure line (L) to line (L) voltages on **GRID** terminals. Ensure $480V_{AC}$ between all phases to each other.

4. Power on the Sol-Ark 60K-3P-480V

1. Turn **ON** the external **GRID** disconnect. Wait for the “**AC**” LED indicator to turn on.
2. Turn **ON** the PV DC disconnect switches. Wait for the “**DC**” LED indicator to turn on.
3. **PRESS** down the power button to the **ON** position. Wait for the “**Normal**” LED indicator to turn on. This may take a few minutes.
4. Turn **ON** the external battery disconnect if the system has batteries.
5. Turn **ON** any external **LOAD** and **GEN** breakers.

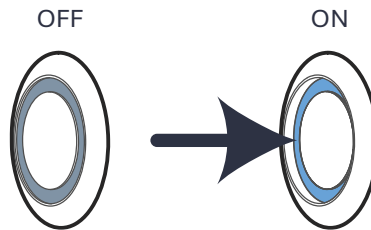

Figure 18: Inverter Power Button Operation

2.13 Power Cycle Sequence

1. **TURN OFF** the external battery disconnect if the system has batteries.
2. **PRESS** the power button, making sure it is in the **OFF** position. An “**OFF**” message will appear after the “**Normal**” LED turns off.
3. **TURN OFF** the built-in PV DC disconnect switches on the side of the inverter.
4. **TURN OFF** all AC breakers / disconnects (**GRID**, **GEN** and **LOAD**).
5. Wait a moment (~1 min) to ensure the inverter is completely de-energized.
6. Make sure that the Sol-Ark is properly connected to the batteries, solar panels, **GRID**, **GEN**, and **LOAD**.
7. Reverse the steps to turn **ON** the Sol-Ark.

3. User Interface

3.1 LED Indicators

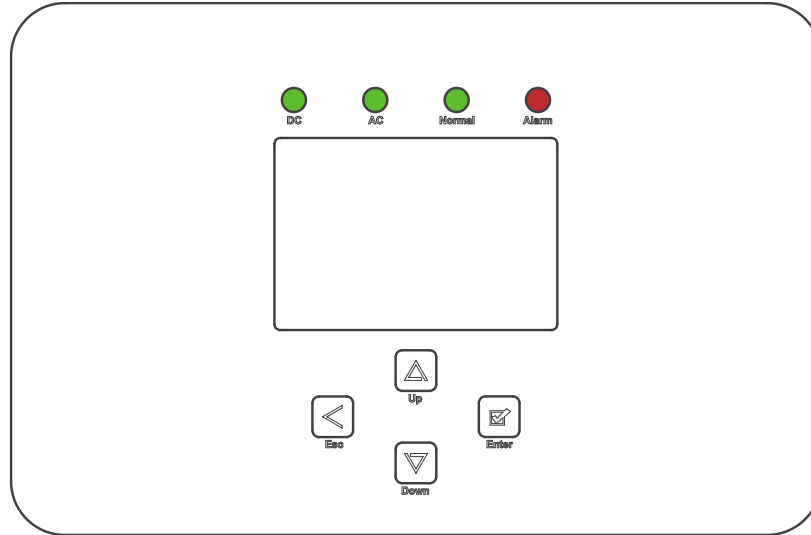

Figure 19: Inverter Front Panel

DC	AC	Normal	Alarm
Green → DC PV input connected and providing voltage.	Green → Grid is connected and providing voltage.	Green → Sol-Ark is fully energized* and operating.	Red → Alarm state. Check the alarms menu. Home Screen → ⚙ → "System Alarms"
OFF → Minimum MPPT voltage not met, wrong polarity or no PV _{DC} .	OFF → Grid voltage out of range or Off-Grid system.	OFF → Not fully energized*, in fault state or in passthrough mode.	OFF → No alarms / error codes / setting change notifications



Note: Fully energizing the inverter requires having at least one of the following:
a. DC PV and Grid **OR** b. Batteries

3.2 Main Menus

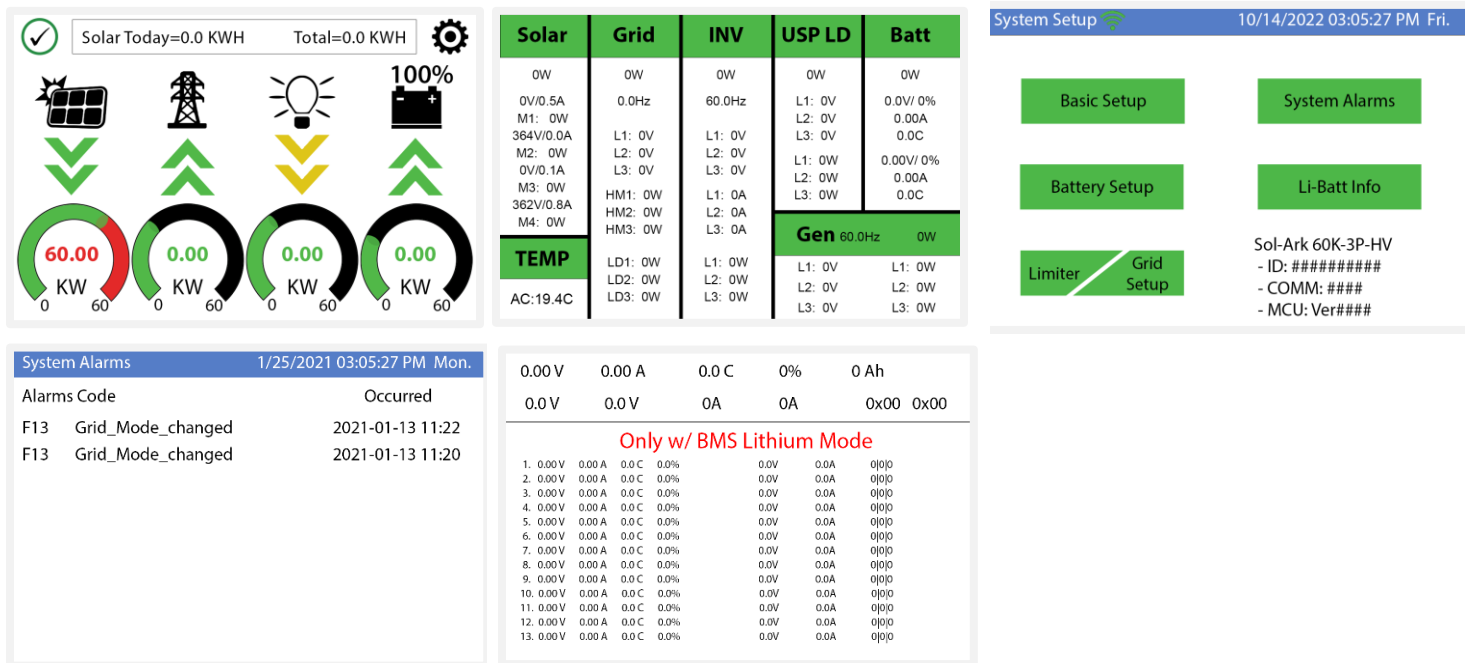

Figure 20: Main Menu Screens Overview

Main Screen

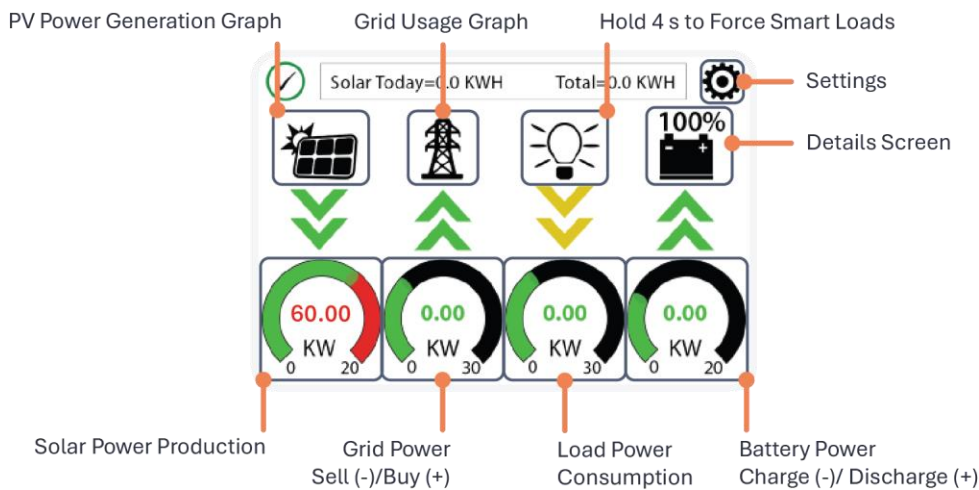

Figure 21: Home Screen Overview

Details Screen

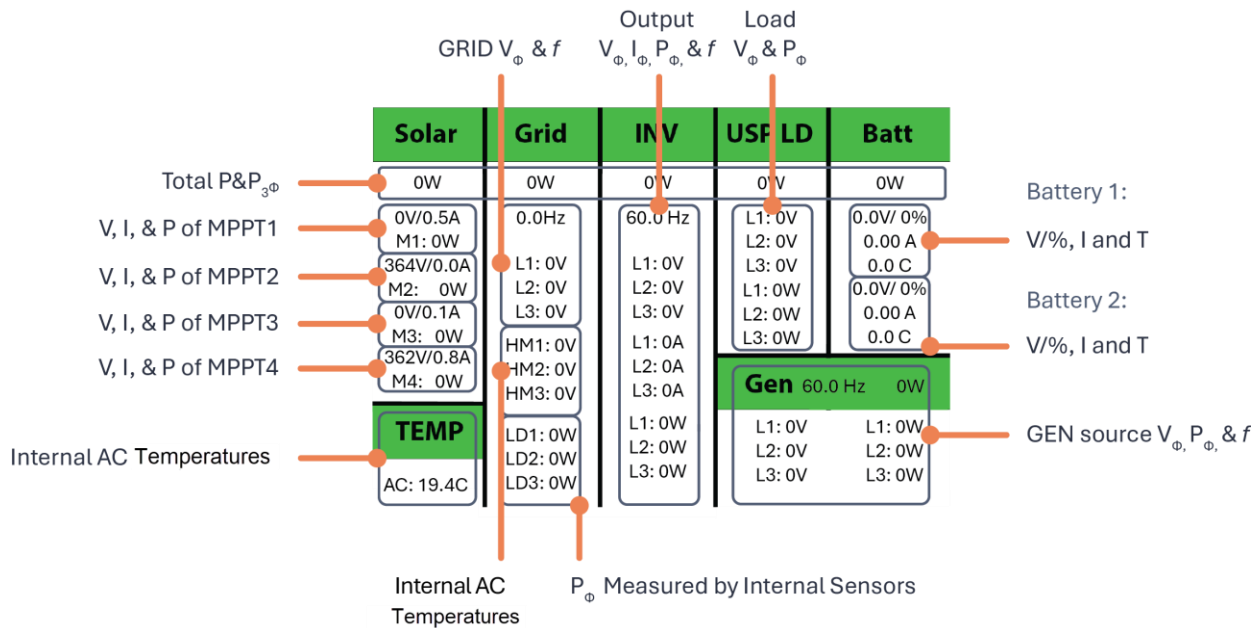

Figure 22: Parameters Screen Overview

⚠ MPPT voltages **MUST NOT** exceed 1,000V.

- **TEMP** measures the internal temperatures of the AC conversion power electronics.
- **Grid** column measures: Voltage, Current, Power and frequency of the utility grid.
 - If selling to the Grid: Watts = negative (-)
 - If buying from the Grid: Watts = positive (+)
 - HM: power measured by the external CT sensors. (L1, L2 & L3).
 - LD: power measured by the internal sensor on **GRID** terminal. (L1, L2 & L3).



NOTE: Opposing “Grid” or “HM” values indicate that CTs are installed incorrectly. See “2.9 Connecting Current Transformers (CT Sensors)” on page 23 for more information.

PV Power Generation Graph

- Tap the solar panel icon to display the PV power generation graph.
- Displays power production over time for the PV array.
- Use up/down arrows (↑, ↓) to navigate between days.
- Month view/year view/total production.

Grid Usage Graph

- Tap the grid icon to display the grid usage graph.
- Displays power drawn from grid (+) / sold to the grid (-).
- Values above the line indicate “power bought” from the grid.
- Values below the line indicate “power sold back” to the grid.
- This view can help to determine when the peak power is used from the grid.

System Setup Menu

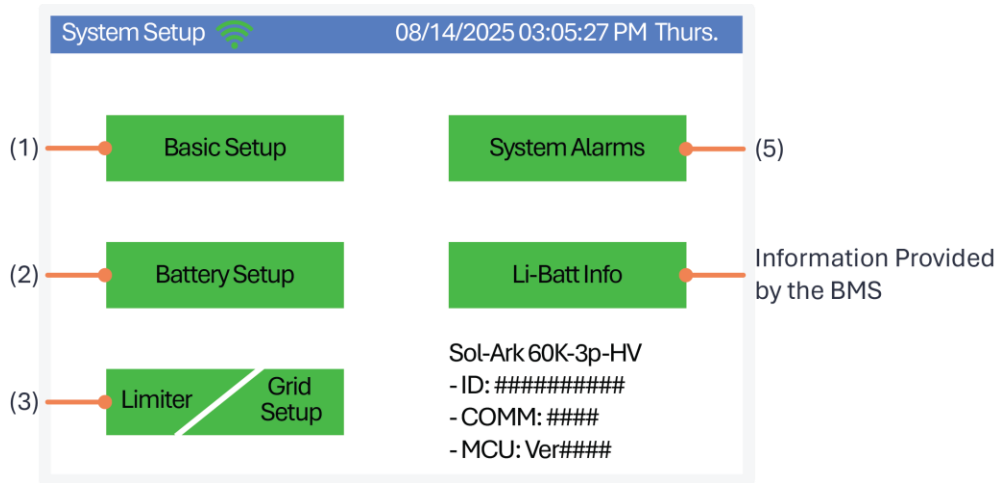
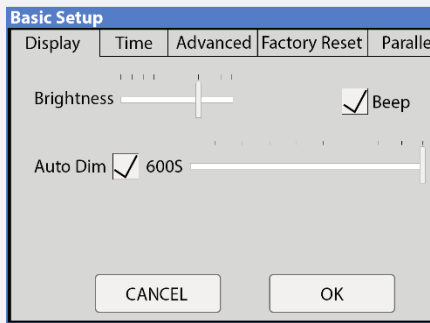

Figure 23: System Setup Screen Overview

3.3 Basic Setup



Basic Setup
 Display | Time | Advanced | Factory Reset | Paralle

Brightness

Beep

Auto Dim 6005

CANCEL OK

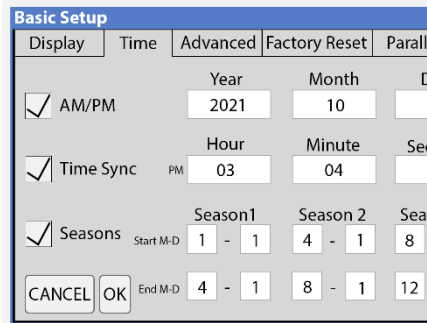

Basic Setup
 Display | Time | Advanced | Factory Reset | Paralle

Year 2021 Month 10 Day 2

Hour 03 Minute 04 Sec 1

Seasons
 Start M-D 1 - 1 Season 1 4 - 1 Season 2 8 - 1
 End M-D 4 - 1 8 - 1 12

CANCEL OK

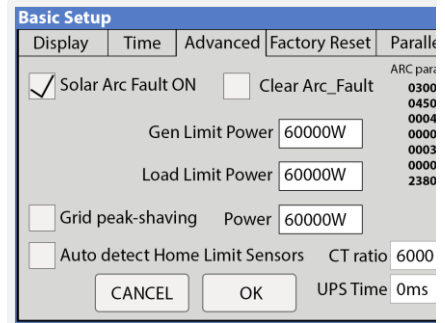

Basic Setup
 Display | Time | Advanced | Factory Reset | Paralle

Solar Arc Fault ON Clear Arc_Fault

Gen Limit Power 60000W

Load Limit Power 60000W

Grid peak-shaving Power 60000W

Auto detect Home Limit Sensors CT ratio 6000

UPS Time 0ms

CANCEL OK

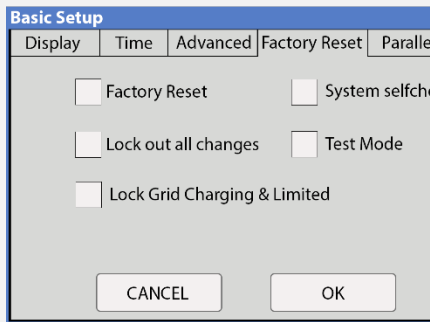

Basic Setup
 Display | Time | Advanced | Factory Reset | Paralle

Factory Reset System selfch

Lock out all changes Test Mode

Lock Grid Charging & Limited

CANCEL OK

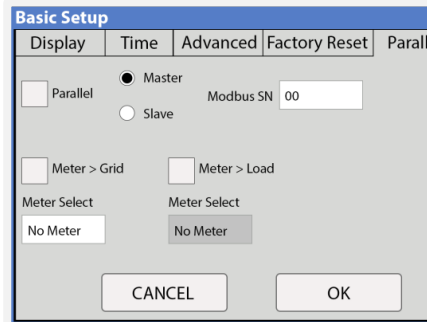

Basic Setup
 Display | Time | Advanced | Factory Reset | Paralle

Parallel Master Slave Modbus SN 00

Meter > Grid Meter > Load

Meter Select No Meter

CANCEL OK

Display

Brightness: Brightness adjustment (+, -).

Auto Dim: ⚠️ Must be always enabled to maintain the warranty of the LCD screen.

Beep: Enable / disable the alarm beep.

Time

Time Sync: Automatically syncs with the internet for daylight saving time changes (Enabling “Time sync” is recommended).

Seasons: Set up and customize the seasons for TOU.

NOTE: This must be programmed using the touch screen; it’s currently not supported on MySolArk.

Advanced

Solar Arc Fault ON: Enables the Arc fault detection algorithm on the MPPTs.

Clear Arc Fault: Command to clear an Arc Fault.

NOTE: This must be executed manually after the system detects an F63 Arc Fault alarm. See “8.1 Sol-Ark Warning and Fault codes” on page 75 for more details.

Gen Limit Power: Limits the power drawn from the **GEN** AC source. The inverter will reduce battery charge when value is reached.

Load Limit Power: Sets a limit to the total **LOAD** output power. The max output power of the inverter is programmed by default.

Grid-Peak Shaving: Sets a **GRID** consumption threshold that allows use of battery backup power during peak demand. External CT sensors are required. Peak shaving can be used on a generator provided it is wired to the **GRID** terminal.

Auto detect home Limit Sensor: Detects and auto-corrects the polarity of the CTs. See “2.9 Connecting Current Transformers (CT Sensors)” on page 23.

CT ratio: Specifies the transformation ratio of the CT. Default value of 6000:1 for the 300A/5A sensors included with the inverter

UPS Time: Backup transfer time to essential loads upon grid disconnection. Default value of up to 15ms.

Factory Reset

Restrictions: Changes to these settings must be previously authorized by Sol-Ark technical support agents.

Parallel

Parallel: Enables communications between parallel inverters. “Master” and “Slave” inverters must be programmed.

MODBUS SN: Identification number for each system configured in parallel (1,2,3,4, n).



NOTE: See section “5. Parallel Inverters” on page 52 for more information.

3.4 Battery Setup

Batt Setup			
Batt	Charge	Discharge	Smart Load
Batt capacity	200Ah	<input checked="" type="checkbox"/> BMS Lithium Batt	01
Max A charge	50A	<input type="checkbox"/> Use Batt V charged	
Max A discharge	50A	<input type="checkbox"/> No Battery	
<input type="checkbox"/> Parallel bat1&bat2			
CANCEL		OK	

Batt Setup			
Batt	Charge	Discharge	Smart Load
StartV	490.0V	490.0V	Float V 552.0V
Start%	30%	30%	
A	40A	40A	
<input type="checkbox"/> Gen Charge <input checked="" type="checkbox"/> Grid Charge			
<input type="checkbox"/> Gen Force			
CANCEL		OK	

Batt Setup			
Batt	Charge	Discharge	Smart Load
Shutdown	170.0V	10%	
Low Batt	165.0V	20%	
Restart	180.0V	50%	
Batt Empty V	160.0V	<input type="checkbox"/> BMS_Err_Stop	
CANCEL		OK	

Batt Setup			
Batt	Charge	Discharge	Smart Load
<input type="checkbox"/> Use gen input as load output		<input type="checkbox"/> For AC Coupled Input to Gen	
<input type="checkbox"/> On Grid always on		High Frz 65.00Hz	
Smart Load OFF Batt			
510.0V	95%		
Smart Load ON Batt			
540.0V	100%		
CANCEL		OK	

Batt

Batt Capacity: Specifies the capacity of the battery bank. Value expressed in Amp Hour (Ah).

! Batteries in series → Voltage adds up (V).

! Batteries in parallel → Capacity adds up (Ah).

Max A Charge: Sets the maximum charge current (A) rate to the batteries when charged from solar power → 50 max allowed. 100A max total if using both battery terminals.

Max A Discharge: Sets the maximum discharge current (A) rate from the batteries → 50A max per port. 100A total if using both battery terminals. For off-grid systems, the battery bank will discharge 120% of this value for a 10 second surge before the inverter faults to prevent battery damage.

BMS Lithium Batt (required): Checked - Default is Protocol number 00 for Sol-Ark L3 Series batteries. Enables closed communications with batteries via CAN bus on BMS1 and BMS2 Ports. You can change the Protocol Number from 00 to another number to allow communication with other battery models.

Use Batt V Charged: Displays battery charge in terms of voltage.

Parallel bat1&bat2: Must be checked when using both battery inputs for the same battery bank. When enabled, the inverter will expect a single battery communication source. See “2.3 Battery Communications” on page 13.

Charge

Float V: Lower steady voltage at which the battery is maintained after being fully charged.

- Not supported for Li-ion batteries.

Gen Charge: Uses the **GEN AC** source to charge the battery bank.

Start V: Voltage at which the system will auto-start and allow a generator or AC source to charge the battery.

Start %: SOC at which the system will auto-start and allow a generator or AC source to charge the battery.

A: Maximum rate of charge to the batteries (per terminal) from the generator or AC source (DC amps). Set the value according to the generator size.

Grid Charge: There are two scenarios in which this option is used:

- **Grid connected to Grid input:** The inverter will limit the charge rate to the set value in **A** and the battery will charge to 100% SOC.
- **Generator connected to Grid input:** You must select **GEN connect to Grid input**. The system will use **Start V**, **Start%** and **A** conditions to charge the battery and stop charging at 95% SOC.
 - Adjustable upper limit if **Time of Use** is enabled.

Gen Force: Test function for generator auto-start. Enable and press **OK** to close normally open relay (CN2, pins 1,2) and force the generator on. Disable and press **OK** to disengage. The generator will not provide power during this test if grid power is available.



NOTE: The genset must be in automatic mode if applicable and must have a two-wire start (dry-contact, normally open) connected to the Sol-Ark.

Discharge

Shutdown: Battery voltage or percentage at which the inverter will shut down to protect the battery from an over-discharge situation (battery symbol on the home screen will turn red).

Low Batt: Low battery voltage or percentage (battery symbol on the home screen will turn yellow). Stopping point for TOU.

Restart: Battery voltage or percentage at which AC output will resume after previously reaching “shutdown”.

Batt Empty V: Sets the empty voltage and associates this voltage to 0% SOC. This value determines the lowest percentage SOC limit.

BMS_Err_Stop: Enables a system stop when battery communications are lost.



CAUTION: Do not exceed GEN port input/output current limit of 180Aac continuous.

Smart Load

This mode uses the **GEN** input as a load output that delivers power when the battery exceeds a user programmable threshold or when the Sol-Ark is connected to the grid.

When **Use gen input as load output** is enabled, the GEN input turns into an output to power high-power loads such as a water heater, irrigation pump, AC unit, pool pump, or any other load.

When **On Grid always on** is enabled, the GEN terminal will always output power as long as the grid is connected, regardless of battery charge.

Smart Load OFF Batt: Battery voltage or % at which the GEN terminal will stop outputting power.

Smart Load ON Batt: Battery voltage or % at which the GEN terminal will start outputting power.

Solar Power (W): Amount of PV production needed before GEN terminal starts outputting power.

AC Coupling Settings (for AC Coupled Input)

 Grid-tied systems with AC coupled solar arrays must have **Grid Sell** enabled. Make sure that you are allowed to sell back to the grid.

To use the **GEN** terminal as an AC coupling input for micro inverters or string inverters, select the check box **For AC Coupled Input to Gen**

 In off-grid systems, the Sol-Ark will use frequency shifting to control the AC coupled solution based on the battery SOC.

3.5 Limiter

The Sol-Ark 60K-3P-480V inverter will simultaneously utilize different available power sources to satisfy load demand in the electrical service panels (essential loads panel/main service panel). The following work modes let the user determine how power is generated and used.

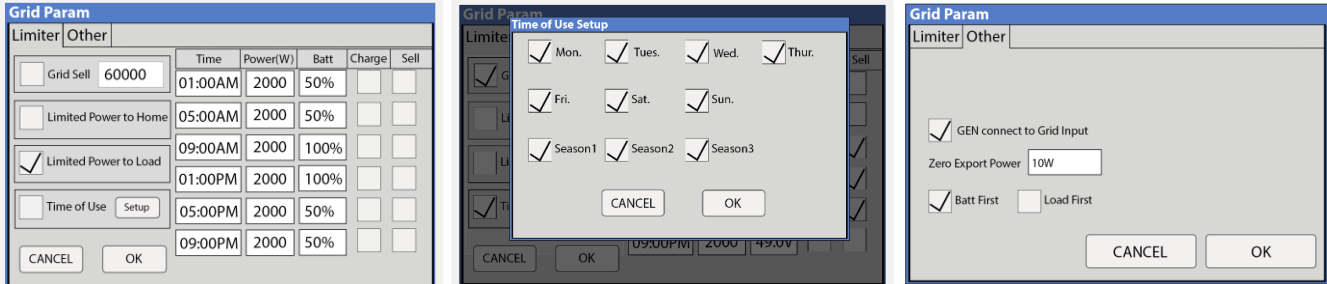

Grid Sell

The inverter will produce as much power as it has available from PV array according to the programming. The maximum power that can be generated from DC coupled arrays and sold to the grid is 60,000W.

Description

This mode allows the inverter to sell back power generated from the solar arrays up to a programmable limit.

- The inverter will measure only loads connected to the **LOAD** terminal.
- The inverter will measure all power in/out of the **GRID** terminal as grid either consumption (+) or grid sell back (-).

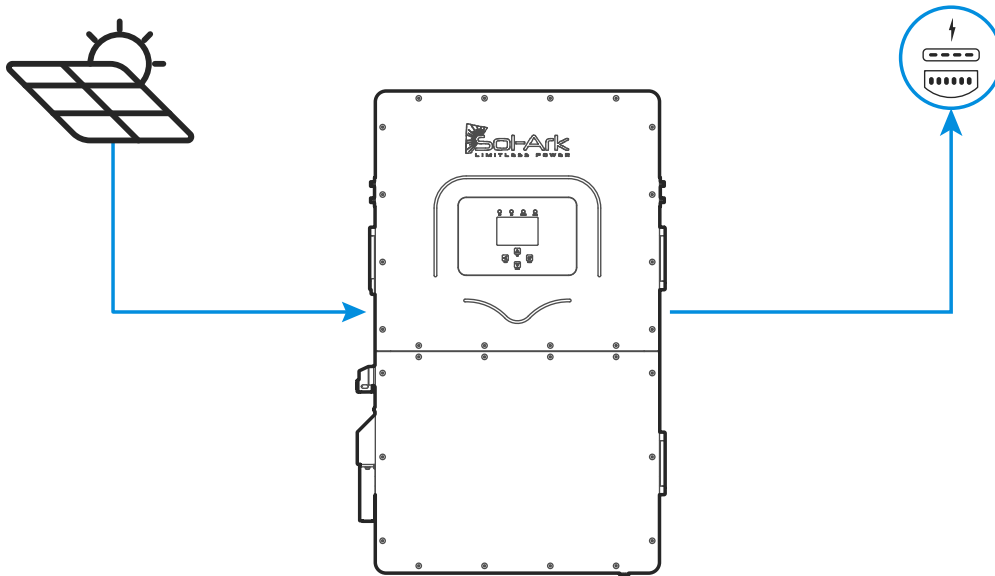



Figure 24: Operating Mode Diagram – Grid Sell

Limited Power to Home



NOTE: This operating mode **REQUIRES** batteries.

Limited Power to Home (Meter Zero)

This mode limits the energy produced by the inverter to satisfy the total demand (essential loads panel + main service panel). In this mode, the inverter delivers power to the **LOAD** terminal (essential loads panel) + the **GRID** terminal (main service panel).

CT sensors **MUST** be installed. These sensors measure load consumption in the main service panel to offset total load demand and prevent selling to the utility. This system work mode is useful for users who don't have a permit to sell back.

See “2.9 Connecting Current Transformers (CT Sensors)” on page 23 for proper external CT installation.

Description

Power is delivered to all home loads without selling excess solar to the grid. This mode is suitable for systems where selling to the utility grid is not allowed.

- External CT sensors are required for proper operation.
- Monitored loads will be the addition of the main service panel + essential loads panel.
- Energy Priority: 1. Solar PV Power | 2. Grid Power | 3. Batteries | 4. Generator

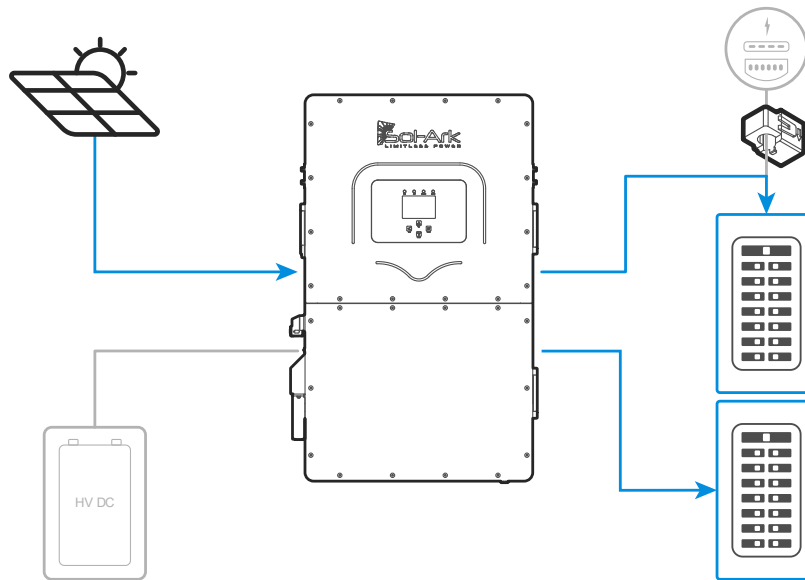

Figure 25: Operating Mode Diagram - Limited Power to Home

Limited Power to Home + Grid Sell

This mode will NOT limit solar production to home demand. In this mode, the inverter delivers power to the **LOAD** terminal (essential loads panel) + excess power to the “GRID” terminal (main service panel AND grid). The Sol-Ark will monitor grid sell and load consumption simultaneously (with +/- 3% error from CT sensors).

The CT sensors **MUST** be installed. The inverter will sell excess solar power up to a programmable limit. See “2.9 Connecting Current Transformers (CT Sensors)” on page 23 for proper external CT placement.

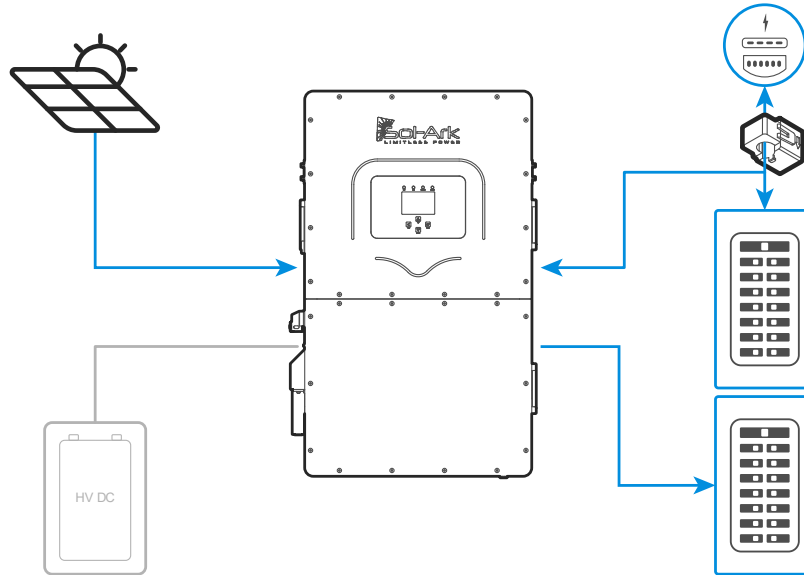

Figure 26: Operating Mode Diagram - Limited Power to Home + Grid Sell

Limited Power to Load

This mode limits the solar production to cover **LOAD** demand (essential loads panel) exclusively. In this mode, the system disregards loads in the main service panel and will not deliver power to the **GRID** terminal.



NOTE: This operating mode **REQUIRES** batteries.

Description

- Power is limited to the **+LOAD** demand. It will **NOT** produce more power than necessary
- Power will **NOT** be delivered to the **GRID** terminal (NO grid sell)
- Monitored loads will be exclusive to the essential loads panel
- This mode is recommended for off-grid applications
- Energy Priority: 1. Solar PV Power | 2. Grid Power | 3. Batteries | 4. Generator

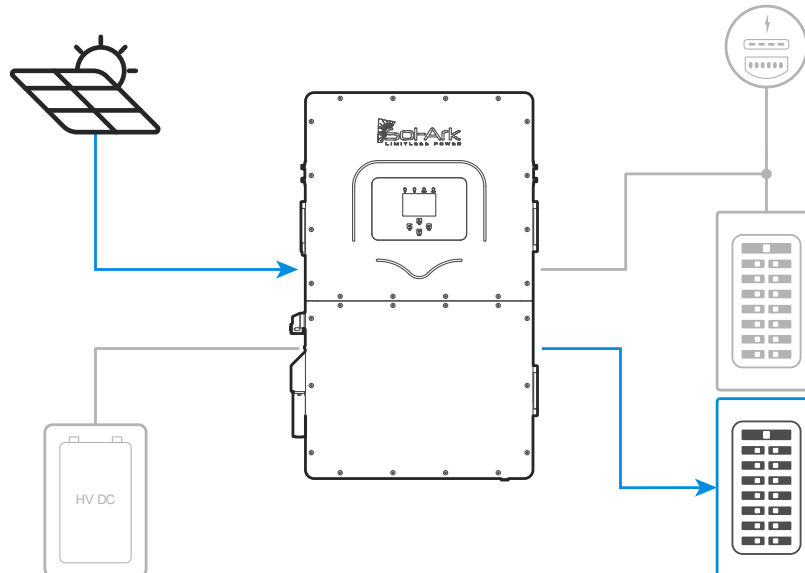

Figure 27: Operating Mode Diagram - Limited Power to Load

Limited to Load + Grid Sell

This mode will NOT limit solar production to **LOAD** demand. The inverter delivers power to the **LOAD** terminal (essential loads panel) + excess power to the **GRID** terminal (main service panel AND grid), however it will track **ONLY LOAD** demand and sell excess solar up to a programmable limit. **GRID** loads cannot be measured, only the total output through the **GRID** terminal.

This mode is recommended for single inverter systems or for whole-site backup installations.

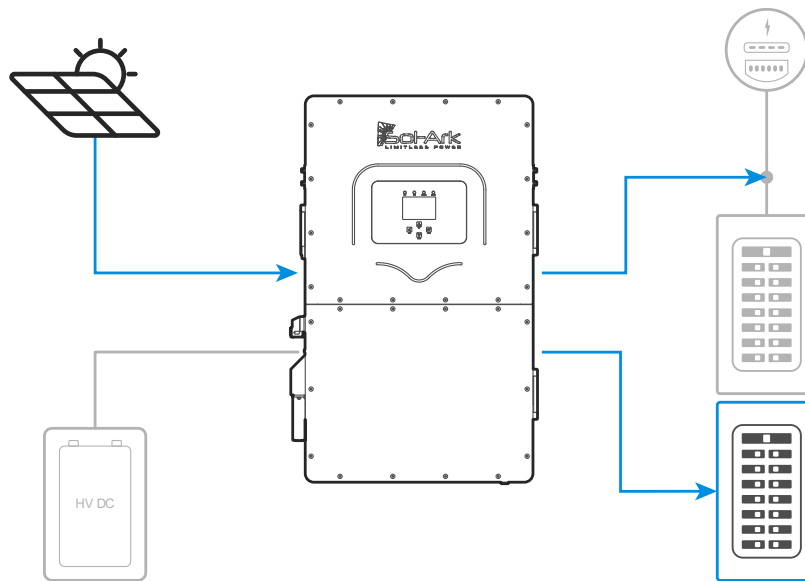

Figure 28: Operating Mode Diagram - Limited Power to Load + Grid Sell

Time of Use

This mode combined with **Limited Power to Home** or **Limited Power to Load** lets you use battery backup power to reduce consumption from the grid during specific time intervals. Battery power will cover load demand at a programmable power rate **Power(W)** down to a programmable **Batt (V / %SOC)**. You can configure six different time intervals over a 24-hour period to cover a wide range of battery discharge or charge behaviors.

Description

This mode uses battery power to reduce the power consumption during user-defined time intervals.

- **Power (W)** dictates the rate at which the battery discharges to assist with load demand.
- **Batt (V or %)** dictates the lower discharge limit or upper charge limit.

Energy Priority: 1. Solar PV Power | 2. Batteries (down to programmed discharge V or %) | 3. Grid Power | 4. Generator

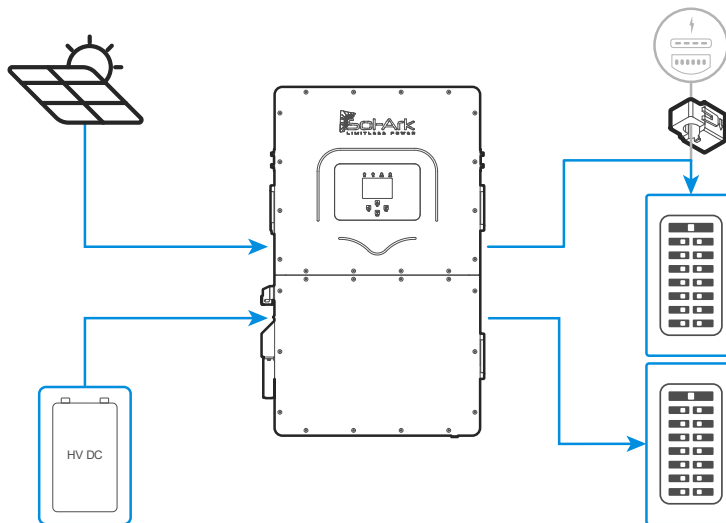

Figure 29: Operating Mode Diagram - Limited Power to Home + TOU

Time: Programmable time intervals over a 24-hour period. All time slots **MUST** follow chronological order and must be programmed.

Power(W): Sets the maximum discharge rate of the battery during the corresponding time slot.

Batt: V or % used to specify a lower discharge limit or upper charge limit whenever **Charge** is enabled.

! Grid-tied systems will not allow TOU to discharge lower than **Low Batt V/%**. Off-grid systems allow TOU discharge down to **Shutdown V/%**.

Charge: During the hours selected, it is allowed to charge batteries from an external AC source up to a programmed voltage or %. If the external AC power source is a generator, the **Start V** or **Start %** condition must be fulfilled first. If available, the solar array will always charge the batteries at 100% regardless of **Charge** in TOU.

Sell: Batteries can discharge and sell power to the grid at the programmable **Power(W)** rate. **Grid Sell** MUST be enabled.

! **NOTE:** Do not enable **Charge** and **Sell** at the same time.

Other

GEN Connect to Grid Input: Specifies when a generator is connected to the **GRID** terminal.

Zero Export Power: Minimum power imported from the grid. Helps avoid selling back by ensuring constant grid consumption. The value can be set between 1 – 100W (recommended 20W).

Batt First: Default and recommended option. Sets the solar power priority of the system to charge batteries first.

Do NOT change unless instructed by Sol-Ark technical support.

Load First: Sets the solar power priority of the system to cover loads demand first and deliver remaining power to batteries.

This is recommended only for very specific situations.

3.6 Grid Setup

Grid Param

Grid Selection | Connect | IP | F(W) | V(W)/V(Q) | P(Q)/P(F)

Grid Mode: 1/3
UL1741 & IEEE1547

Grid Frequency: 50Hz, 60Hz

Grid Reconnect Time: 300s

Fixed PF: 1.000, Fixed Q: 0%

Q_Response_T: 5.0s

Grid Level: LN:277V/LL:480V(AC)

Phase Type: 0/240/120

CANCEL OK

Grid Param

Grid Selection | Connect | IP | F(W) | V(W)/V(Q) | P(Q)/P(F)

Reconnect

Grid Vol High: 504.0V, Grid Vol Low: 422.4V, Grid Hz High: 60.1Hz, Grid Hz Low: 59.5Hz, Reconnect Ramp rate: 300s

Normal connect

Grid Vol High: 576.0V, Grid Vol Low: 240.0V, Grid Hz High: 65.0Hz, Grid Hz Low: 50.0Hz, Normal Ramp rate: 300s

CANCEL OK

Grid Param

Grid selection | Connect | IP | F(W) | V(W)/V(Q) | P(Q)/P(F)

Over Voltage U>(10 min. running mean): 239.2V

HV3: 576.0V, HV2: 576.0V, HV1: 528.0V, LV1: 422.4V, LV2: 240.0V, LV3: 240.0V

HF3: 65.00Hz, HF2: 65.00Hz, HF1: 63.00Hz, LF1: 57.00Hz, LF2: 50.00Hz, LF3: 50.00Hz

CANCEL OK

Grid Param

Grid selection | Connect | IP | F(W) | V(W)/V(Q) | P(Q)/P(F)

Over frequency: Start freq F: 60.04Hz, Start delay: 0.50s, Droop F: 42%PE/Hz, Stop freq F: 60.04Hz, Stop delay: 0.50s

Under frequency: Start freq F>: 59.96Hz, Start delay F>: 0.50s, Droop F>: 42%PE/Hz, Stop freq F>: 59.96Hz, Stop delay F>: 0.50s

F(W)

CANCEL OK

Grid Param

Grid selection | Connect | IP | F(W) | V(W)/V(Q) | P(Q)/P(F)

V(W) V(Q)

Response_T: 5s

V1:106.0%, V2:110.0%, V3:110.0%, V4:110.0%

P1:100%, P2:0%, P3:0%, P4:0%

Lin:5.0%, Lout:20.0%

V1:92.0%, V2:98.0%, V3:100.0%, V4:106.0%

Q1:44%, Q2:0%, Q3:0%, Q4:44%

CANCEL OK

Grid Param

Grid selection | Connect | IP | F(W) | V(W)/V(Q) | P(Q)/P(F)

P(Q) P(F)

P1:20%, P2:50%, P3:100%, P4:100%

Q1:100%, Q2:100%, Q3:100%, Q4:100%

Lin:5.0%, Lout:100.0%

P1:50.0%, P2:100.0%, P3:100.0%, P4:100.0%

F1:1.000, F2:0.800, F3:0.800, F4:0.800

CANCEL OK



WARNING: Consult your utility before changing grid interconnection settings.



DANGER! SHOCK HAZARD: Ensure inverter settings for are correctly configured for 480V Delta or 277/480V Wye Service. Failure to configure the inverter correctly could lead to equipment failure, shock hazard, and/or serious injury.



DANGER! DO NOT USE WITH 240V DELTA HIGH LEG SERVICES: Delta High Leg or "Wild Leg" 3-phase systems have an unbalanced phase-to-neutral voltages that can severely damage the 60K inverter if connected, leading to equipment failure and/or serious injury.

Grid Selection

Grid Mode: Tap and use navigation arrows to cycle through different grid modes:

1. **General Standard:** Applies general grid interconnection standards. Enables grid frequency and voltage adjustments.
Note: This is useful for off-grid applications with backup generators.
2. **UL1741 & IEEE1547:** Applies UL 1741 and IEEE 1547 grid interconnection requirements and standards.
3. **CPUC RULE21:** Applies California’s grid interconnection requirements and standards.
4. **SRD-UL-1741:** Applies UL 1741SB grid interconnection requirements and standards.

Grid Frequency: Frequency of the AC sine wave.

Grid Reconnect Time: The amount of time in seconds the inverter will wait before reconnecting to the grid.

Fixed PF: Allows for power factor correction, ± 0.8 to 1.0

Fixed Q: Allows for power factor correction based on desired reactive power percentage.

Grid Level: Tap and use navigation arrows to cycle through different nominal grid voltage levels.

⚠ Grid level must be selected according to nominal grid voltage.

1. **Most Common:** LN:277VAC LL:480VAC
2. LN:230VAC LL:400VAC
3. LN:220VAC LL:380VAC

Phase Type: Tap and use navigation arrows to specify phase sequence.

1. **Most Common:** 0/240/120: Positive sequence A-B-C
2. 0/120/240: Negative sequence A-C-B

IT system-neutral is not GND: Configures an inverter to operate in either a Wye or Delta configuration (see “Figure 27: Operating Mode Diagram - Limited Power to Load” on page 44).

1. **480V Delta Configuration (3W no neutral):** **Checked**
2. **277/480V Wye Configuration (3W with neutral):** **Un-Checked**

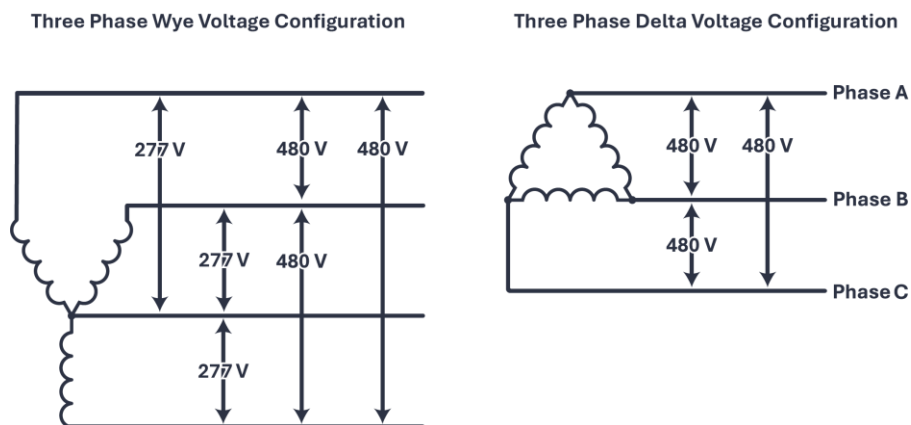

Figure 30: Wye versus Delta Voltage Configuration

Connect

Reconnect: Parameters used to determine an allowable range of frequency and voltages to dictate a reconnection to the grid after initial grid loss. Frequency and voltages must be within these margins during Grid Reconnect Time to allow grid reconnection.

 Parameters will be set automatically based on selected grid mode compliance, unless “**General Standard**” is selected.

Normal connect: Parameters used to determine an allowable range of frequency and voltages to retain connection to the grid following a reconnect and normal operation.

 Parameters will be set automatically based on selected grid mode compliance, unless “**General Standard**” is selected.

Reconnect Ramp Rate: Reconnection power ramp time in seconds.

Normal Ramp Rate: Startup power ramp time in seconds.

IP

HV1/HV2/HV3: Overvoltage protection point.

LV1/LV2/LV3: Undervoltage protection point.

HF1/HF2/HF3: Over frequency protection point.

LF1/LF2/LF3: Under frequency protection point.

F(W)

F(W): Enables the use of Frequency-Watt. The Sol-Ark regulates its power output to the grid as a function of the frequency to support grid stabilization during over and under-frequency conditions.

Droop F: Percentage of inverter’s nominal power increase / decrease per Hert (Hz).

Start freq F: Frequency at which the inverter will start decreasing active power by the programmed Droop F percentage.

Stop freq F: Frequency at which the inverter will stop decreasing active power by the programmed Droop F percentage.

V(W) / V(Q)

V(W): Enables the use of Volt-Watt. The Sol-Ark regulates active power output to the grid as a function of voltage to support stabilization during over and under-voltage conditions.

V(Q): Enables the use of Volt-VAr. The Sol-Ark regulates reactive power output to the grid as a function of the voltage to support stabilization during over and under-voltage conditions.

V, P & Q: Percentage of nominal grid voltage (V) to which the Sol-Ark will reduce its active power (P) or reactive power (Q).

P(Q) / P(F)

P(Q): Enables the use of Watt-VAr to regulate reactive power output according to programable active power parameters.

P(F): Enables PF regulation according to programmable active power parameters.

4. Installation Tips

Off-Grid Installation

1. Limit sensors (CTs) are not required for completely off-grid installations unless using **Grid Peak Shaving** for a generator connected to the **GRID** terminal.
2. Connecting generators to the **GRID** terminal is recommended to facilitate the integration **GEN** connected service panel. This setup enables the utilization of the **Smart Load** function.
3. There is no need for a transfer switch. Connect the **LOAD** output to the main panel.
4. **DO NOT** use **Grid Sell** mode when Off-Grid. **ONLY Limited Power to Load** (default).
5. When using a Generator in an Off-Grid situation, it is recommended to change the **Grid Mode** to **General Standard** and a **Grid Reconnect Time** to 30 seconds. See “2.5 Integrating a Generator” on page 17 for detailed instructions.
6. The **Auto Gen-Start** activates when the battery voltage (V) or percentage (%) reaches the pre-set **Start V / %** value. After that, the generator will sustain the charging process until the batteries reach approximately 95% capacity.
 - ! This is a non-modifiable upper limit unless Time of Use is enabled and programmed.
7. Remember to set the battery capacity and reasonable charge/discharge rates.

Grid-Tie PV Only, No Battery Configuration

1. Check the **No Battery** setting: ⚙️ → **Battery Setup** → **Batt** → **No Battery**. The inverter will fault momentarily.
2. ! A complete **Power Cycle IS REQUIRED** when changing the battery mode to **No Battery**. See “2.13 Power Cycle Sequence” on page 32 for instructions.
3. Enable **Grid Sell**: ⚙️ → **Limitter** → **Grid Sell**. Make sure to disable all other modes.
4. Tap the battery icon to access the **Details** screen and verify grid parameters and power import/export.

4.1 Battery Charge Controller

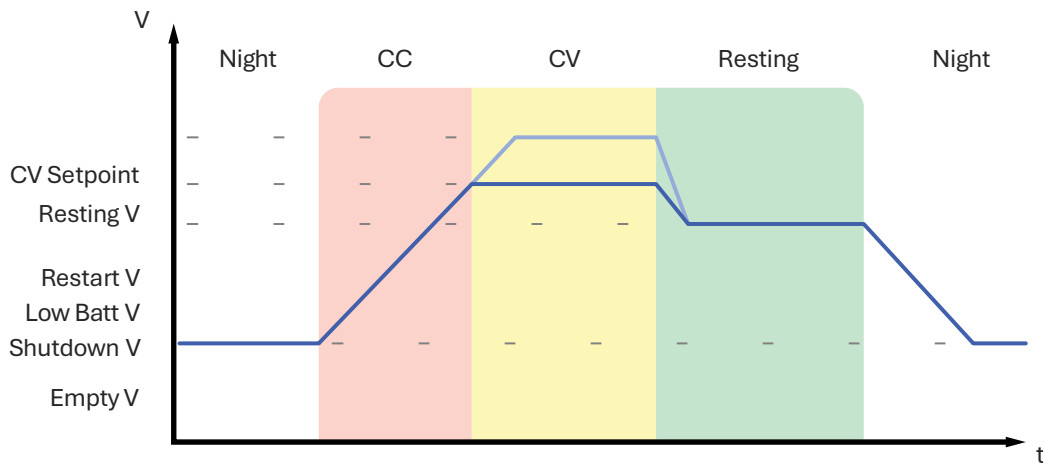

Figure 31 Charge Controller Curve

2-Stage Charging

The MPPT charge controller is 2 stage (CC/CV) type controlled by the BMS when in closed loop mode for optimized and safe charging. Fig 33 shows the charging stage sequence.

Constant Current (CC) Stage

In the Constant Current stage, the battery is not at a 100% state of charge and has not yet reached the Constant Voltage setpoint. The controller will deliver 100% of available solar power to recharge the battery.

Constant Voltage (CV) Stage

When the battery has reached the Constant Voltage setpoint, the Sol-Ark inverter will regulate charging current to maintain the batteries voltage at the CV setpoint, preventing overcharging. The battery is allowed to come to a full state of charge at the CV setpoint. Constant Voltage lasts until the BMS sets the Charge Current Limit to 0A.

4.2 Grid Compliance Settings

For required local Grid Compliance settings, see the application notes on the [Sol-Ark Knowledge Hub](#).



CAUTION: Do not exceed continuous **GEN** port input/output of 180Aac.



CAUTION: Settings below are illustrative, exact values should be confirmed with your utility.

5. Parallel Inverters

5.1 Before Enabling Parallel Operations

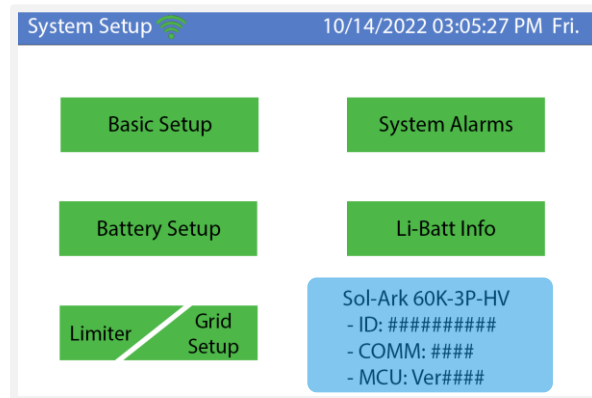

Figure 32: Software Version

- A. Make sure all units in parallel have the same firmware version by verifying the **COMM** and **MCU** numbers on the **System Setup** screen, (highlighted in blue).
- B. To ensure you have the latest firmware, visit <https://www.Sol-Ark.com/resources/software-updates/> to schedule an update, or contact Sol-Ark Technical Support.
- C. ⚠️ Parallel systems **REQUIRE** that each inverter has its own HV battery / battery bank. **FAILING TO INSTALL BATTERIES MAY DAMAGE THE INVERTERS.**
- D. If you do not have batteries on all inverters only parallel the units which have a battery bank. All other units should be set to **Grid Sell** under **Settings**→**Limiter**.
- E. All **GRID**, **GEN**, and **LOAD** ports must be electrically paralleled with **ALL** parallel inverters.

DIP Switch Configuration for Parallel Systems

In parallel systems, set the DIP Switches according to the table below.

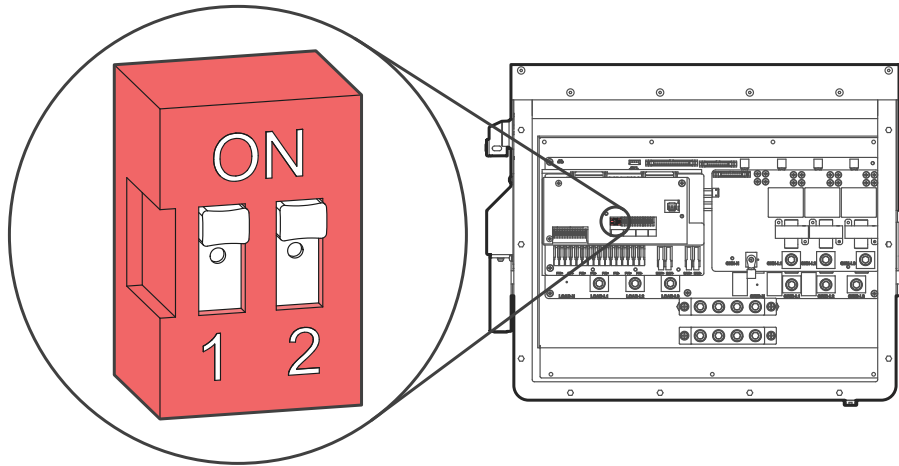

Figure 33 Inverter Communication Settings DIP Switch

Inv 1 (Master)	Inv 2	Inv 3	Inv 4	Inv 5	Inv 6	Inv 7	Inv 8	Inv 9	Inv 10
OFF									
ON	ON								
ON	ON	ON							
ON	ON	ON	ON						
ON	ON	ON	ON	ON					
ON	ON	ON	ON	ON	ON				
ON	ON	ON	ON	ON	ON	ON			
ON	ON	ON	ON	ON	ON	ON	ON		
ON	ON	ON	ON	ON	ON	ON	ON	ON	
ON	ON	ON	ON	ON	ON	ON	ON	ON	ON

Parallel System Output Specifications 277/480V 3-Phase

# of inverters in parallel	Continuous output power (kW)	Cont. Grid Pass Through Current (A)	Peak power 10 sec (kVA)
1	60	180	90
2	120	360	180
3	180	540	270
4	240	720	360
5	300	900	450
6	360	1080	540
7	420	1260	630
8	480	1440	720
9	540	1620	810
10	600	1800	900

5.2 Parallel Systems Programming

1. Program each inverter for parallel operation: ⚙️ → **Basic Setup** → **Parallel** → **Parallel**
2. Assign a **“Master”** inverter, **Modbus SN: 1**
3. Assign all other units as **“Slave”** | **Modbus SN: 02, 03, 04...etc.**
4. Connect communication cables between the inverters using the included RJ45 cable in daisy-chain configuration between ports: **“Parallel_1”** or **“Parallel_2”** from **Master** to **Slave** and then from **Slave** to **Slave** after that.
5. Perform a power cycle (see **“2.13 Power Cycle Sequence”** on page 32 for instructions).
6. Once the power cycle is completed, turn on the **“Slave”** units **FIRST**. Then turn ON the **“Master”** **LAST**.
7. Inverters will likely fault momentarily with F29 and F41 codes until all inverters are ON.



NOTE: When integrating a generator, it must be connected to all the systems in parallel. The inverter assigned as **“Master”** will control the two-wire start feature so the generator contacts should be connected to this inverter only.

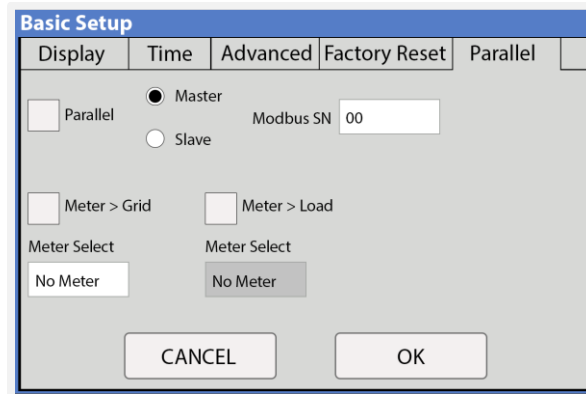

The screenshot shows the 'Basic Setup' window with the 'Parallel' tab selected. The 'Parallel' checkbox is checked. The 'Master' radio button is selected, and the 'Modbus SN' field contains '00'. There are also checkboxes for 'Meter > Grid' and 'Meter > Load', both of which are unchecked. Below these are two 'Meter Select' dropdown menus, both set to 'No Meter'. At the bottom are 'CANCEL' and 'OK' buttons.

Figure 34 Parallel Setup Tab



NOTE: If an inverter goes into a fault state, all other units will stop and the system will automatically try to restart. If the system faults 5 consecutive times, it will stop completely and it will require a manual restart. See **“2.13 Power Cycle Sequence”** on page 32 for detailed instructions.

5.3 Troubleshooting Phase Sequence

▲ If the screen of the Sol-Ark inverter shows the error in Figure 35, make sure that the phase sequence follows the “Phase Type” programmed under ⚙️ → **Grid Setup** → **Grid Selection**. The message “Grid Phase Wrong” is displayed when the inverter does not detect the correct phase sequence. This situation can cause overloads faults in the system (F18, F26, F34) even with the “LOAD” disconnected and **WILL CAUSE DAMAGE** to the equipment if it is not corrected.

If the programmed phase type is “0/240/120”, ensure the wiring follows a positive sequence **A-B-C**. If the programmed phase type is “0/120/240” ensure the wiring follows a negative sequence **A-C-B**.

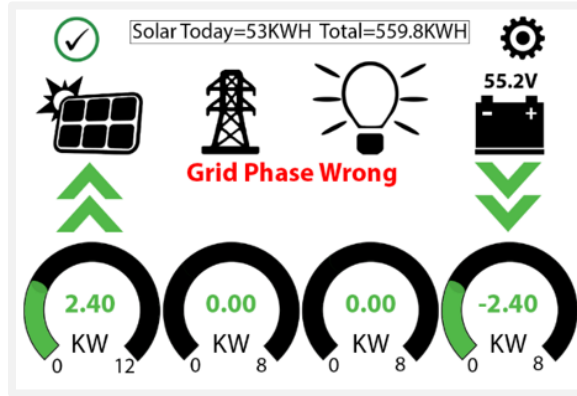

Figure 35 Grid Phase Wrong Error

Troubleshooting Grid Phase Wrong

- Measure L-L voltages from **GRID** to **LOAD** terminals.
- Voltage between lines should be 0Vac.
- Measuring a voltage different than 0Vac means the lines are not the same phase.

Be sure to check both **GRID** and **LOAD** terminal connections; both must be correct. If the error remains, check your AC connection beyond the inverter, and verify that the phases are correctly labeled from your meter.

0/240/120

0/120/240

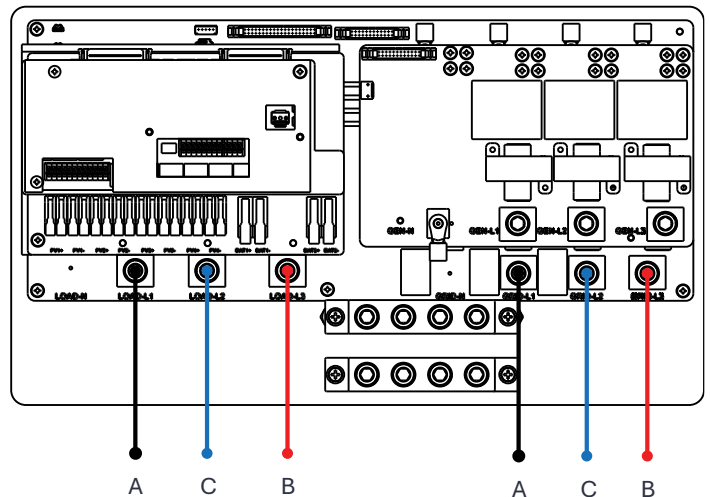
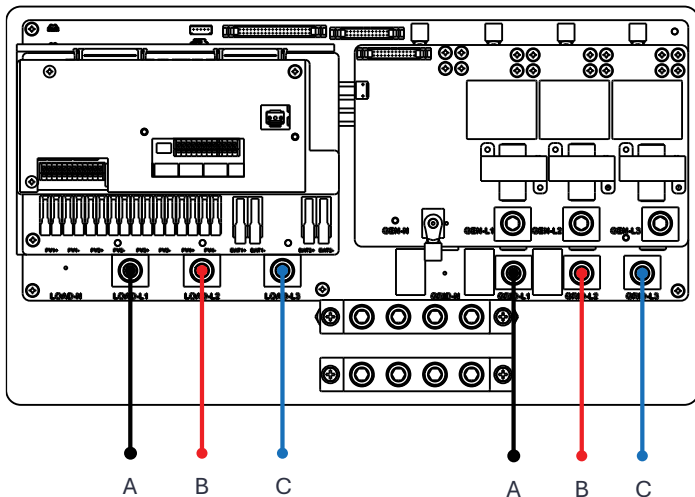

6. MySolArk: Remote Monitoring



MySolArk is a powerful and comprehensive tool designed for remote system monitoring of Sol-Ark inverters and solar systems. This remote monitoring solution offers detailed insights into energy generation and power consumption, allowing users to track system performance with great precision. MySolArk displays all relevant electrical data on easy-to-understand energy generation graphs, providing a comprehensive overview of electrical usage.

Beyond its monitoring capabilities, MySolArk offers the flexibility to remotely adjust inverter settings, allowing you to seamlessly configure your system from any location. This ensures that you can fine-tune parameters to optimize performance effortlessly. With MySolArk, you can confidently manage your solar systems and inverters to always ensure peak performance and efficiency.

Go to www.mysolark.com to access the desktop version.

6.1 MySolArk Setup Instructions

Connecting to MySolArk through Ethernet

- Remove the plastic enclosure of the dongle by pressing the plastic latches with a flat screwdriver as shown in the figure below.
- Insert the ethernet cable through the plastic enclosure and connect the cable to the RJ45 port.
- Reassemble the dongle housing and plug the dongle into the Sol-Ark, securing it with screws. You'll see solid red and green lights after a couple of minutes.
- Follow the "Step 1" instructions on the next page to create a plant on MySolArk.

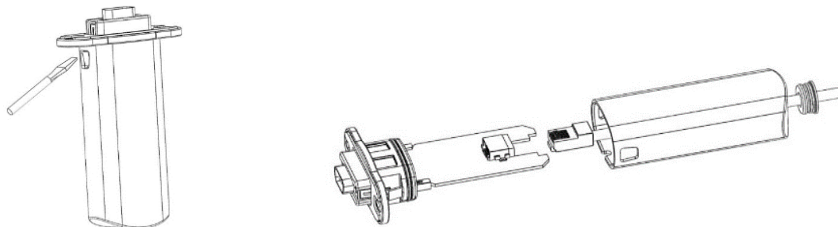

Connecting to MySolArk through Wi-Fi

- Plug the Wi-Fi dongle into the Sol-Ark DB-9 port.
- Use two M4X10 screws to secure the dongle to the port.
- Follow Steps 1-3 in order to:
 - Create a plant on the MySolArk monitoring platform.
 - Connect the dongle to MySolArk through a Wi-Fi network.

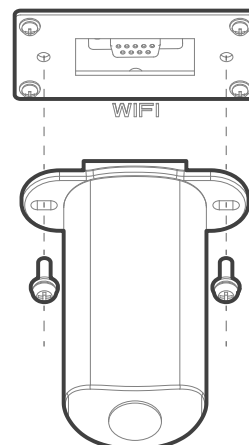

Step 1: Create a “Plant” on MySolArk

A. **Download and install the MySolArk app** for android or apple smartphones. QR codes are provided below.



B. Create a MySolArk account and log in.

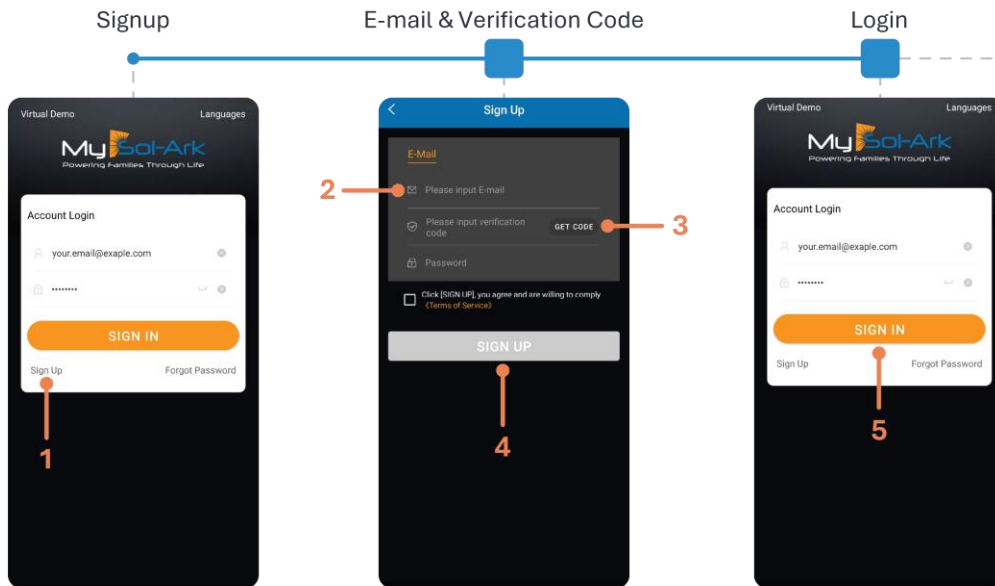

C. Create the Plant.

For Installers:
 Create the plant and configure the system before sharing it with the owner.
 After creating and configuring the plant, the installer can share and grant manager permissions to the owner by navigating to **My Plants** → ... → **Share** → **Add Account**.
 The homeowner must create their own **MySolArk** account first.

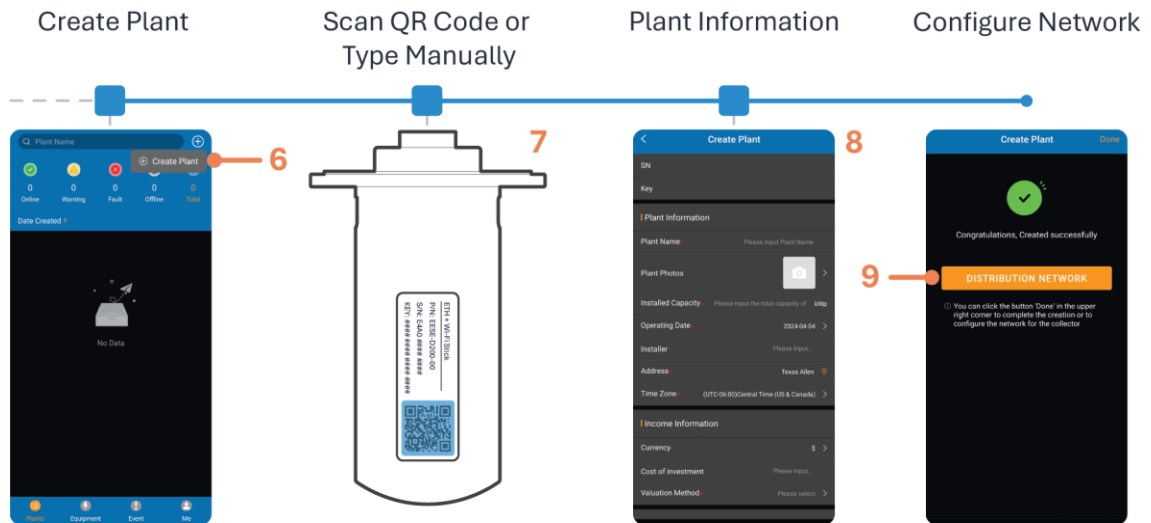

Step 2: Configure Wi-Fi network through MySolArk

D. Configure Wi-Fi network.

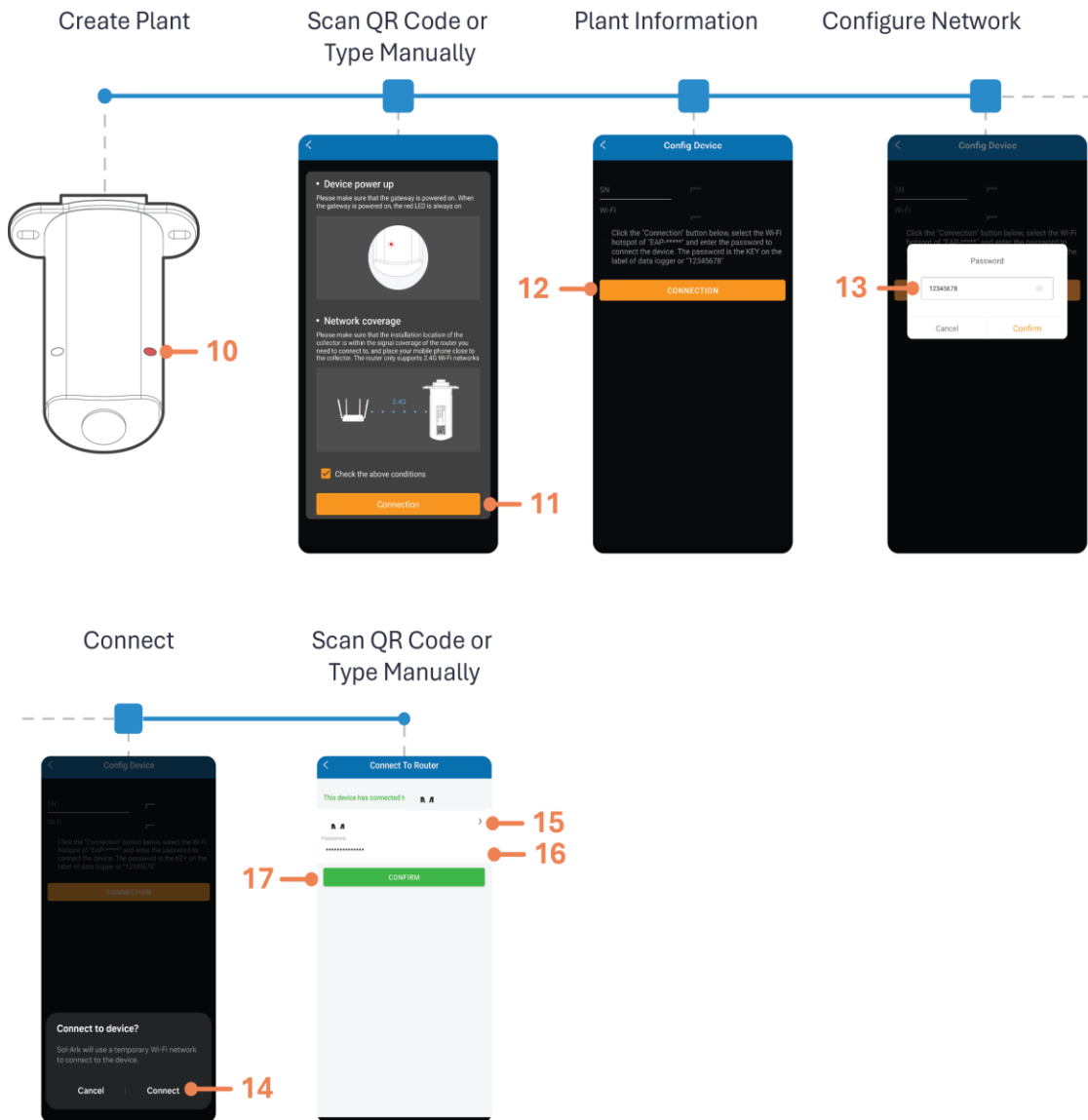

Note: You can access the Wi-Fi configuration tool at any other time by tapping **Me** at the bottom right corner, then **Tools** → **Wi-Fi configuration**. Step 3 shows another method of connecting the Wi-Fi dongle to a local network through an IP address.

Step 3 (alternate method): Configure Wi-Fi Network Through an IP Address

An alternative to the “Distribution Network” configuration at the end of Step C, or using the **Wi-Fi configuration** tool, you can configure a Wi-Fi network through an IP address.

- A. On a Smart Phone or Computer, connect to the **EAP-#####** network.
Go to: **Settings > Wi-Fi > EAP-##### network**.
- B. Type in the password, which depends on the product you received:
 - If you see **“KEY” printed on the dongle**, the 16-digit password is printed there
 - If there is no **“KEY” printed on the dongle**, the password is **12345678**

The EAP-##### network contains the last 5 digits of the Dongle serial number. You can find this number on the label.

- C. A message such as “Connected without internet” appears when the device is connected to the EAP-#####.

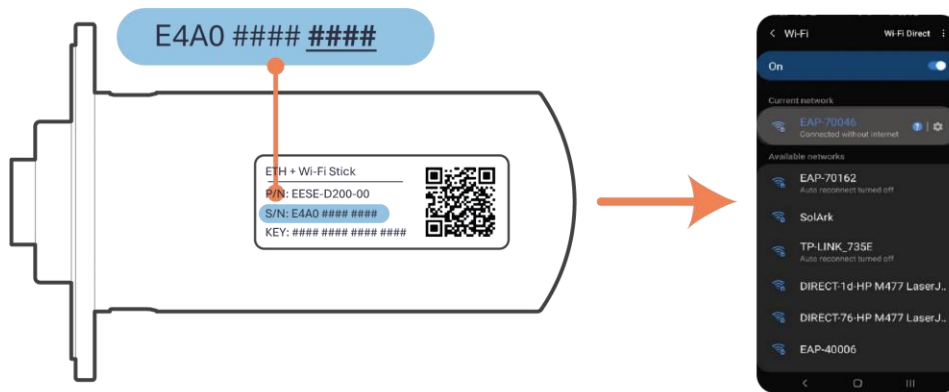
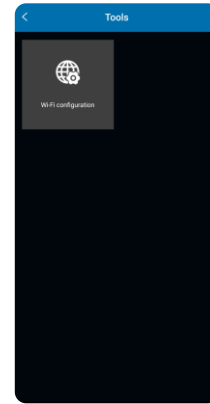

Locating the Dongle Network Name



NOTE: The Wi-Fi dongle does NOT provide internet access. It needs an external internet provider to connect to. The dongle is compatible with Wi-Fi signal broadcasted at 2.4 GHz (it is not compatible with 5 GHz networks)

- D. After you’re connected, open an internet browser on the same device, such as Safari, Chrome, Firefox, Edge, or any other browser.
- E. On the address bar (http://.....), type the IP address: **10.10.10.1** as shown in the figure below. If you cannot access the configuration page, try again on a different device.
- F. Scroll down to the **“Wlan Connection”** section and tap the **Scan** button to scan for local Wi-Fi networks.
- G. Nearby Wi-Fi networks will appear. Select the local network you want to connect to, input your credentials, and tap **Connect**.
- H. Once connected, a “Connection Successful” message appears. Tap the **Save** button next to **Scan** to save settings.
- I. Wait about 5 minutes. The dongle will connect to the Wi-Fi network and will then have access to MySolArk.



NOTE: DO NOT connect to the EAP-##### network as that is the Wi-Fi dongle itself. The device does not provide internet access.

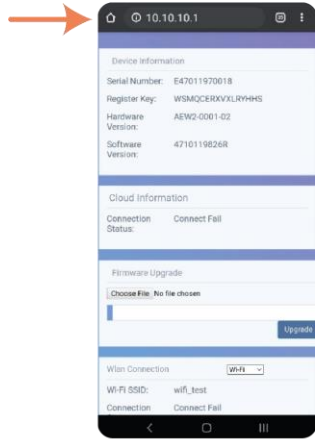

a. Internet Browser IP Address

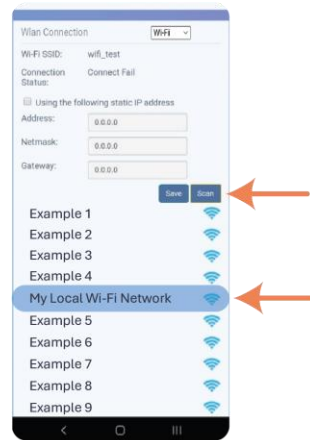

b. Wi-Fi Network Scan

If the connection succeeds, you'll see the following LED indicators.

SOLID : Connected and powered by the Sol-Ark inverter.

SOLID : Connected to the router and to MySolArk.

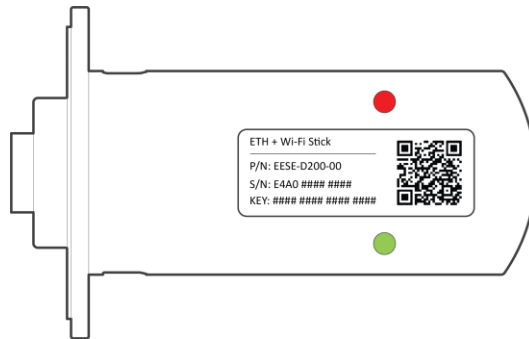

Wi-Fi Dongle LED Indicators





NOTE: Local Dongle Connection
 Connecting through the local hotspot broadcast by the dongle is only meant to provide access to the Wi-Fi dongle for troubleshooting or firmware updates.
 Users must still create a MySolArk account and must create a Plant to access monitoring data.

6.2 LED Indicator and Troubleshooting

When both the red and green LEDs on the Wi-Fi dongle are consistently lit, it signifies normal operation, while flashing indicates data transmission. If this isn't the case, reference the next table of LED indications for troubleshooting and corrective measures.

 **RED LED:** Device communication indicator.

 **GREEN LED:** MySolArk server communication indicator.

LED	State	Indication
	Initial flashing, then constant illumination	Normal communication.
	Initial flashing but no further illumination	Communication failure. Check proper device connection.
	LED not illuminating	Power supply or device is abnormal. Contact technical support.
	5 second illumination interval	Normal communication.
	1 flash every minute	Router not connected.
	3 flashes every minute	Connected to router but no internet access. Usually, a VPN or firewall issue. Ports 80 and 51100 must be enabled.
	4 flashes every minute	Device communication error. Contact Sol-Ark Support.
	2 synchronized flashes	Ethernet cable inserted
	3 synchronized flashes	Ethernet cable disconnected

7. Wiring Diagrams

CAUTION: The following diagrams are general use cases. Please remember that it's mandatory to adhere to local electrical codes and regulations.



While these diagrams offer general guidance, they may not encompass all variations and specifics required by local codes. Consult with relevant authorities and ensure compliance before proceeding with any installation.

The diagrams in the following pages are not exhaustive and should not be relied upon solely for permitting or warranty verification. Please use caution, seek professional advice when necessary, and undertake installations with due diligence and in accordance with established electrical standards and regulations.



WARNING: Use only designated cable entry points. Drilling or altering the chassis without Sol-Ark written authorization will void any warranty and may adversely affect performance and safety.

7.1 Standard Wiring Diagram

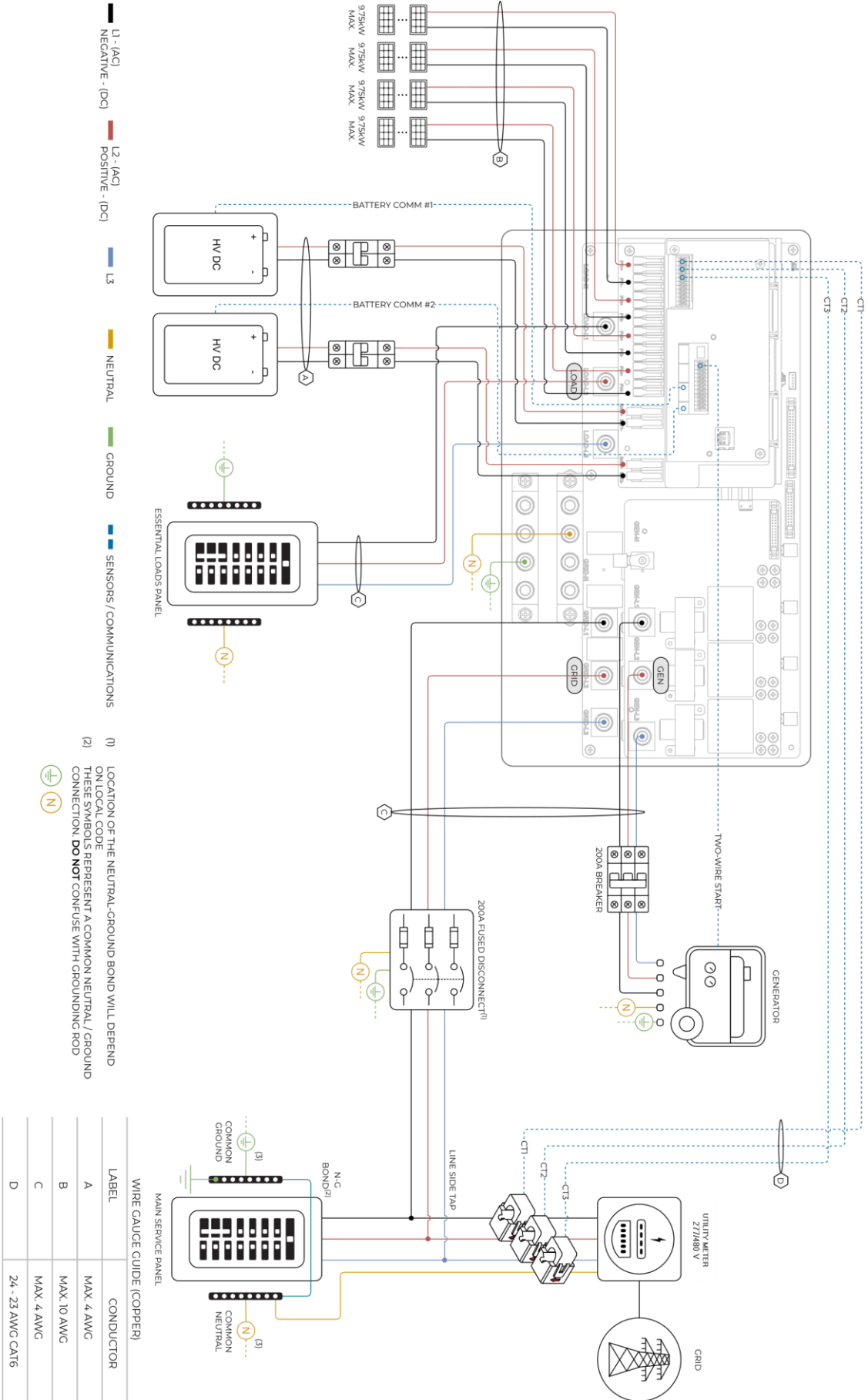

- (1) LOCATION OF THE NEUTRAL-GROUND BOND WILL DEPEND ON LOCAL CODE
 THESE SYMBOLS REPRESENT A COMMON NEUTRAL / GROUND CONNECTION. **DO NOT** CONFUSE WITH GROUNDING ROD
- (2)

WIRE GAUGE GUIDE (COPPER)	
LABEL	CONDUCTOR
A	MAX. 4 AWG
B	MAX. 10 AWG
C	MAX. 4 AWG
D	24 - 23 AWG CAT5

Diagram 01

7.3 Standard Wiring Diagram – AC Coupling

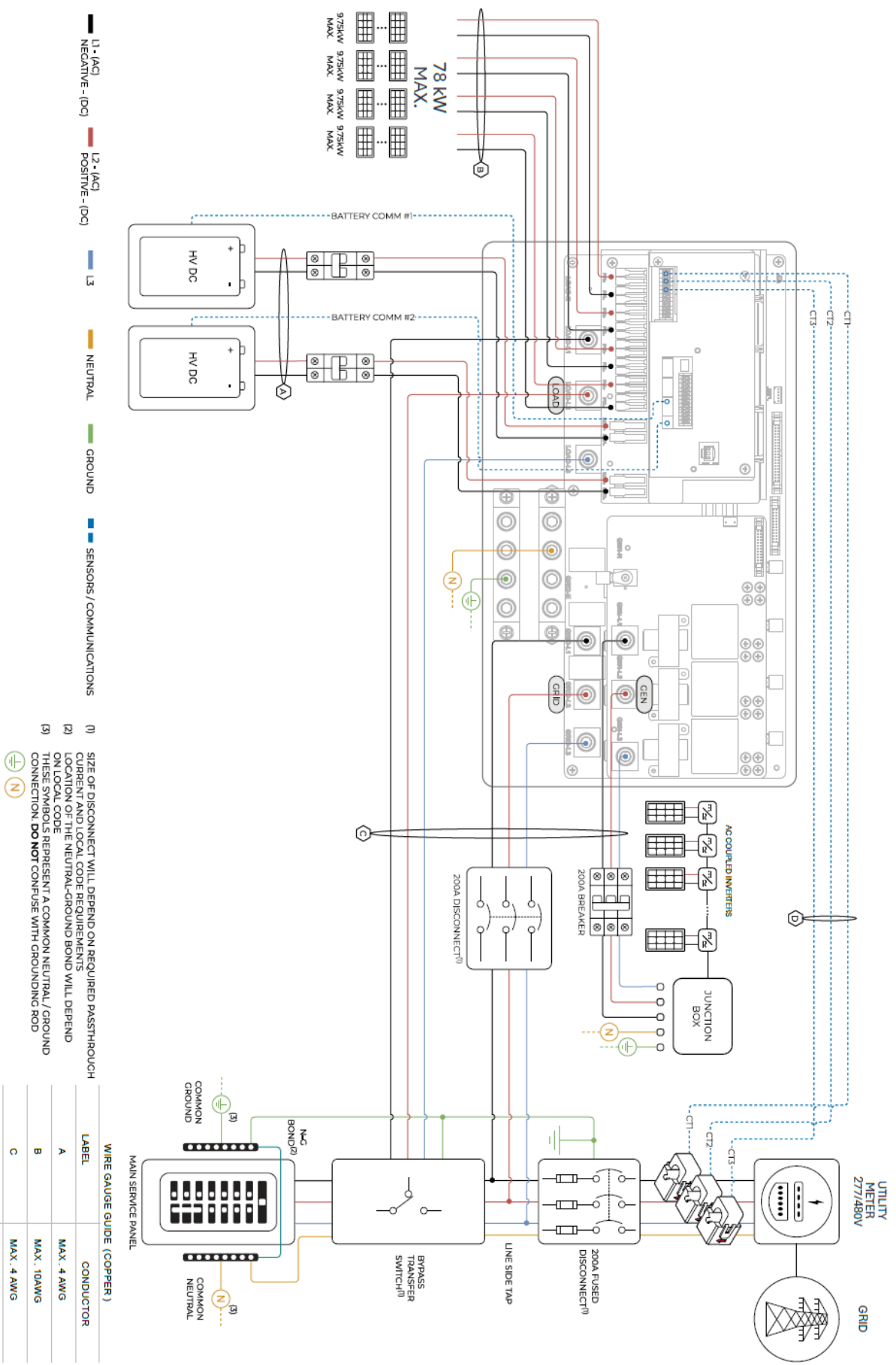

Diagram 03

7.4 Standard Wiring Diagram – Bypass Transfer Switch

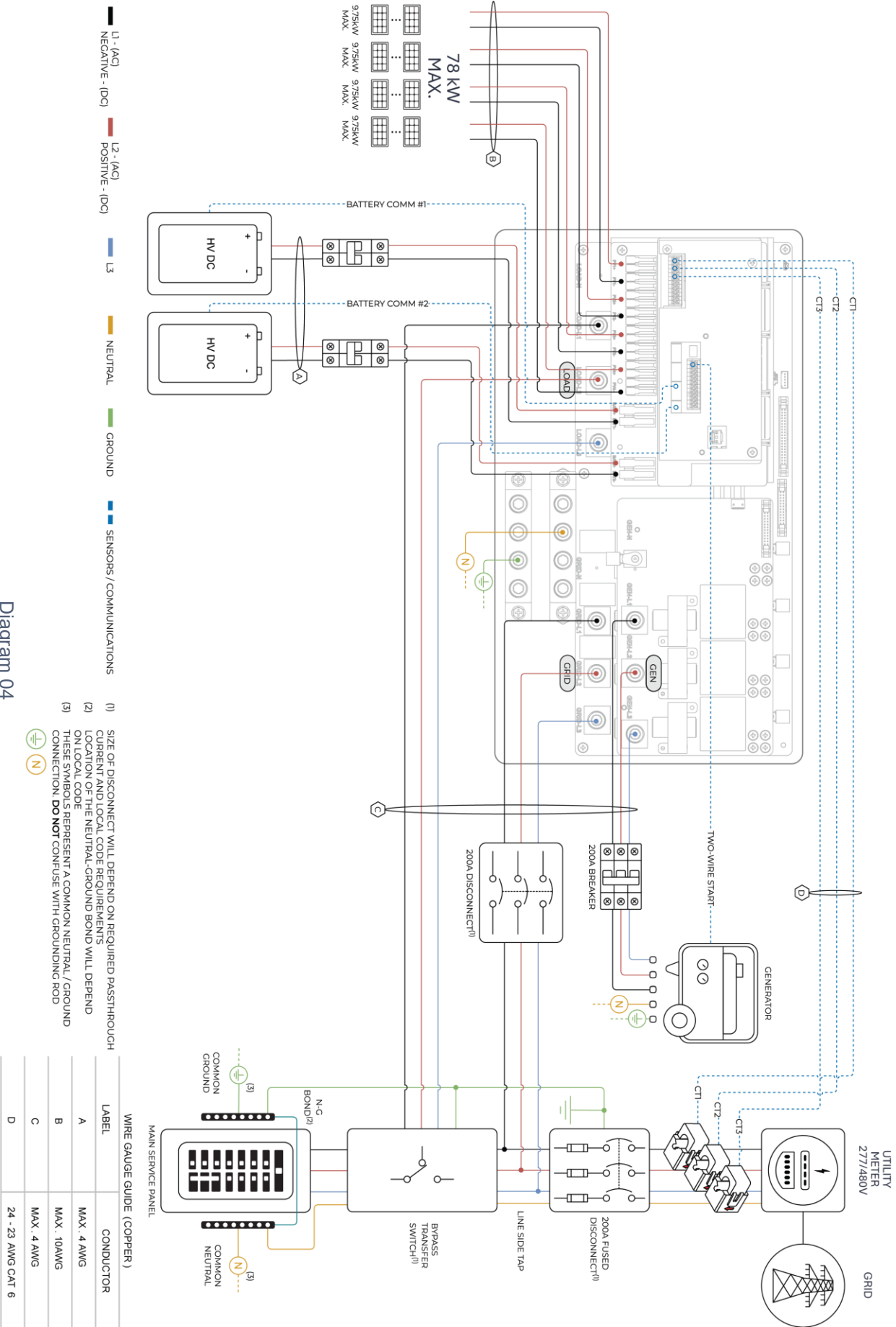
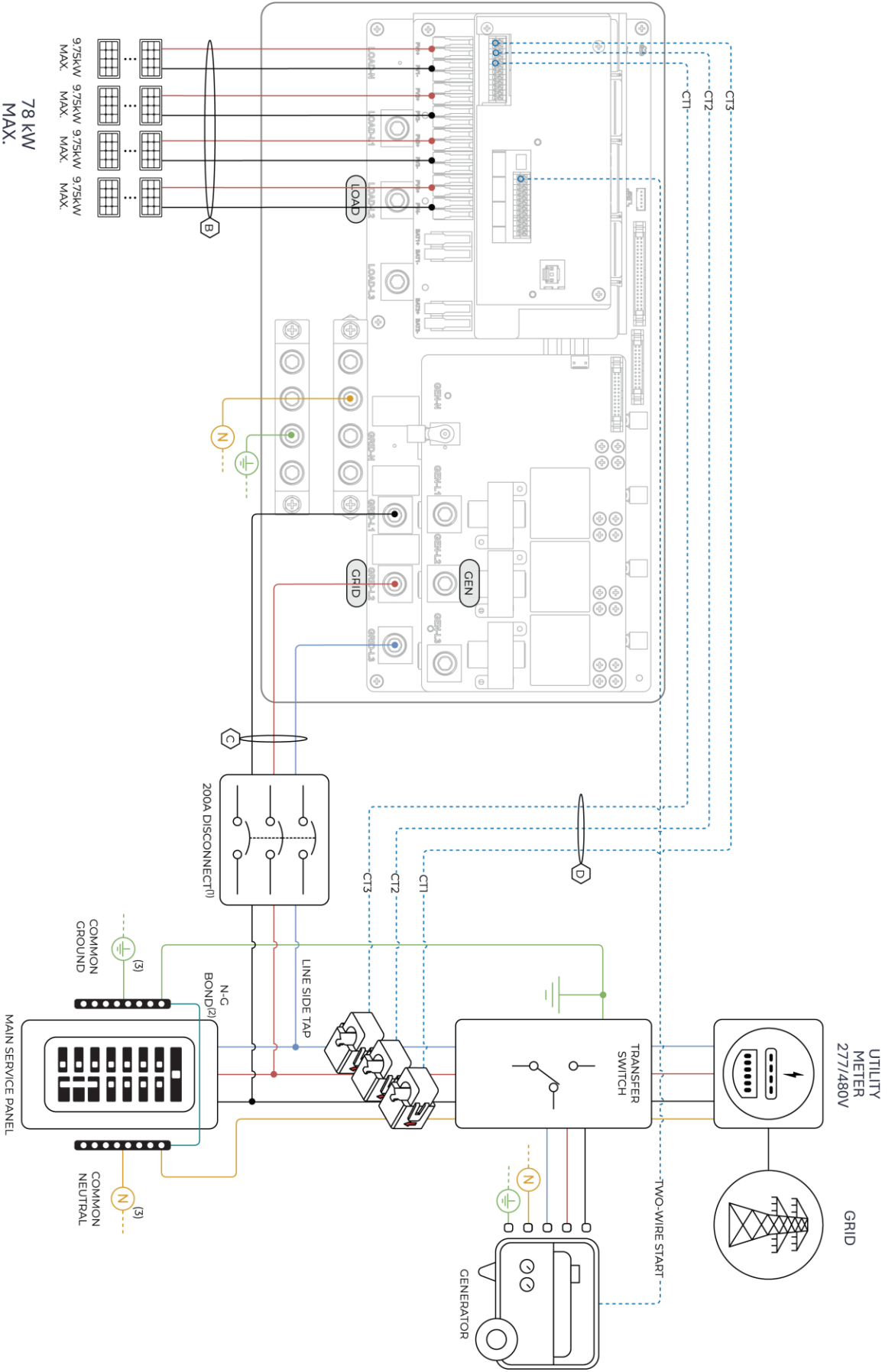

Diagram 04

7.6 Standard Wiring Diagram – Grid-Tied Only with Standby Generator



78 kW
MAX.

- U - (AC) NEGATIVE - (DC)
- L2 - (AC) POSITIVE - (DC)
- L3
- NEUTRAL
- GROUND
- SENSORS / COMMUNICATIONS

- (1) SIZE OF DISCONNECT WILL DEPEND ON REQUIRED PASTTHROUGH CURRENT AND LOCAL CODE REQUIREMENTS
- (2) LOCATION OF THE NEUTRAL-GROUND BOND WILL DEPEND ON LOCAL CODE
- (3) THESE SYMBOLS REPRESENT A COMMON NEUTRAL / GROUND CONNECTION. **DO NOT** CONFUSE WITH GROUNDING ROD

WIRE GAUGE GUIDE (COPPER)	
LABEL	CONDUCTOR
A	MAX. 4 AWG
B	MAX. 10AWG
C	MAX. 4 AWG
D	24 - 23 AWG CAT 6

Diagram 06

7.7 Standard Wiring Diagram – 2 Parallel Inverters, Standard Wiring

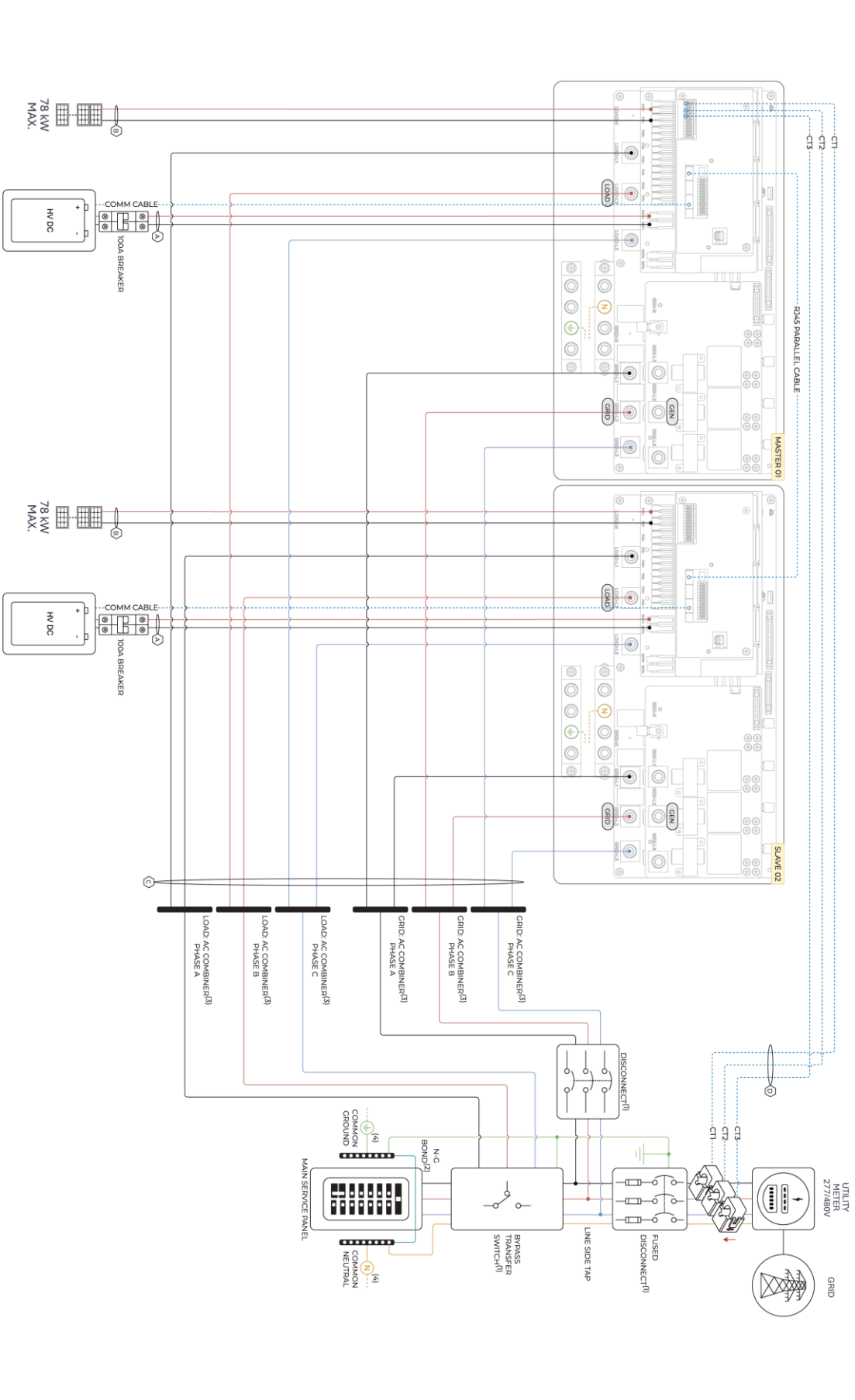

- (1) SIZE OF DISCONNECT WILL DEPEND ON REQUIRED PASSTHROUGH CURRENT AND LOCAL CODE REQUIREMENTS
- (2) LOCATION OF THE NEUTRAL-GROUND BOND WILL DEPEND ON LOCAL CODE
- (3) THESE SYMBOLS REPRESENT A COMMON NEUTRAL / GROUND CONNECTION. **DO NOT** CONFUSE WITH GROUNDING ROD

WIRE GAUGE GUIDE (COPPER)	
LABEL	CONDUCTOR
A	MAX. 4 AWG
B	MAX. 10AWG
C	MAX. 4 AWG
D	24 - 23 AWG CAT 6

Diagram 07

1 Before powering up Parallel System installs, see section "5. Parallel Inverters"

7.8 Standard Wiring Diagram – 3 Parallel Inverters, Standard Wiring

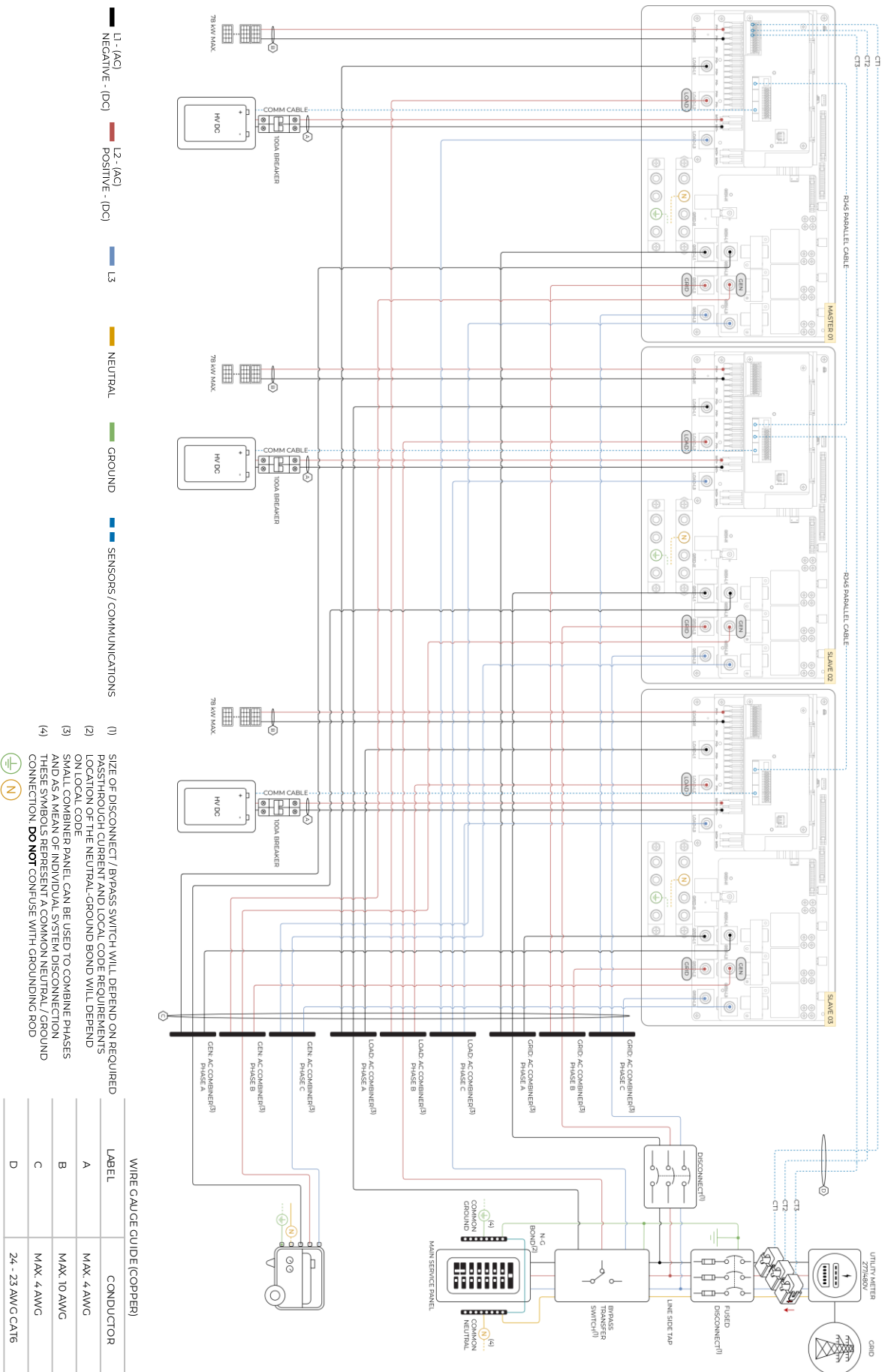

Diagram 08
1 Before powering up Parallel System installs, see section "5. Parallel Inverters"

8. Common Troubleshooting Steps

LCD is not powering on

- Check all connections – at least one of the following power sources is required: PV/Grid/Battery
- Try pressing the power button, touchscreen, or navigation buttons

Panels are connected, but “DC” LED indicator is not on

- Startup voltage is 180V. Voltage must be above 180V and below 1,000V
- Wrong polarity. Check string polarity on MPPT
- PV DC disconnect switches are not on the ON position

Panels are not producing

- Check for proper wiring on all solar panel connections
- Turn PV disconnect switches "ON"
- Check that the PV input voltage is not greater than 1,000V
- If the system measures 0V even when PV DC disconnect is ON, polarity might be wrong. Check PV polarity

Panels are not producing much power

- PV Wire Strip Length: 5/8". Your batteries are charged and is limited to house loads; you can test Grid Sell to verify.

The system does not keep batteries charged

- Verify there is proper communication between the Sol-Ark and the battery. : ⚙️ → **Li-Batt Info**
- Verify proper Charge and Voltage settings according to battery manufacturer and battery bank arrangement

Auto Gen-Start is not working

- Make sure the generator has a compatible Two-Wire
- Verify adequate connection to the Sol-Ark auto-start input pins

“Normal” LED indicator is not on

- Sol-Ark is in pass-through mode (only Grid connection and no other power source)
- Not fully energized (DC Solar panels AND Grid or batteries only)
- In alarm state.
- Sol-Ark is not working correctly (Call Sol-Ark Technical Support at +1 (972) 575-8875 ext. 2

The “Alarm” LED indicator is on

- Check the system alarms menu to identify the alarm

Grid HM value is negative when it should be positive (only applies in Limited to Home mode)

- Limiter Sensors are backwards, L1/L2/L3 sensors are swapped, or incorrectly wired. Execute the “**Auto Learn Home Limit Sensors**” command described in “2.9 Connecting Current Transformers (CT Sensors)” on page 23.

AC Overload Fault or Bus Unbalance Fault

- Check Transfer Switch/Subpanel wiring
- Check for large loads that consume more than the inverter rating

The system connects to grid and quickly disconnects

- Verify Neutral wire connection (0Vac referenced to GND)
- Check the programmed frequency, and verify the Sol-Ark measures 277V between L and N
- If the system is overloading: verify the proper phase sequence between **GRID** and **LOAD** terminals

DC Overload Fault

- Check PV voltage. Ensure no more than 1,000V
- Make sure you have not wired more than 2 solar strings in parallel per MPPT

System is beeping

- Check the System Alarms menu to see which alarm has been triggered. Most alarms will self-reset
- Do a Power Cycle as described in “2.13 Power Cycle Sequence” on page 32.

Battery cable sparks when connected

- If applicable, flip the built-in breakers of the battery bank before connecting or disconnecting batteries

Battery symbol on the home screen is red

- The battery is below the empty voltage
- Battery is over-voltage or under-voltage

Battery symbol on the home screen is yellow

- The battery is low, or the charge/discharge current is close to the programmed limit

Grid symbol on the home screen is yellow

- Grid parameters are out of specified operating range
- There is a grid outage and there is no voltage on the **GRID** terminal
- System is Off-Grid

System has restarted

- Occurs when the system has overloaded, battery voltage has surpassed 800V
- There was a Software update

Batteries were connected backwards

-  System may be damaged and warranty will be void

Why is the LCD screen still on when the power button is off?

- Occurs when the power button is in the “OFF” position
- Occurs when the system is not fully energized: PV or Grid only

The Batt SOC% is not reaching 100%

- BMS communication is not working properly. Verify with battery integration and communication steps

Generator setup is reading 0Hz

- Generator is operating at a frequency outside the permissible range.
- Select **General Standard** grid mode. Widen the frequency range to 55Hz-65Hz as described in “2.5 Integrating a Generator” on page 17.

Color touchscreen is frozen

- Press and hold the escape button [◀] for 7-10 seconds
- Perform a power cycle sequence in case the above suggestion does not work. See “2.13 Power Cycle Sequence” on page 32 for instructions.

Grid Phase Wrong

- ⚠ If the Sol-Ark screen shows a “Grid Phase Wrong” message, it means there is a phasing issue in the wiring. If left uncorrected, it may cause overload faults and **DAMAGE**. See “5.3 Troubleshooting Phase Sequence” on page 55 for more information.

8.1 Sol-Ark Warning and Fault codes

Fault	Description	Common Cause/Remedy
W03	Grid_Phase_Warn	Grid phasing sequence error. Verify that the order of the three GRID input phases are in the order A-B-C, or change the phase setting value on the LCD.
W04	Meter_Offline_Warn	Communication failure with external revenue grade meter. Verify that the meter is powered on and the RJ45 connection is secure.
W31	BMS_LostComm_Warn	Contact Sol-Ark Technical Support.
W32	Parallel_Comm_Warn	The quality of parallel inverter communication is poor. Communication is possible, but there may be packet loss. Verify if the DIP switch of each inverter is set to "ON." Check the length of the parallel communication cables: the length should not be more than 16ft (5m) between inverters.
F1	DC_Inversed_Failure	Verify that the PV input wires are not reverse polarity. If you have parallel systems and turn one system off, you will get this notification.
F8	GFDI_Relay_Failure	Check for continuity on the inverter's neutral and ground. Make sure that there is only ONE neutral-to-ground bond in the system. For Current Leakage from inverter AC output to Ground, check that Ground and neutral are connected at the main panel.
F13	Grid_Mode_change	This notification can appear when not using batteries or if Grid Input settings are changed. This is a notification, NOT a fault. If you switch from No Batt to Battery mode, power the system down completely to restart.
F15	AC_OverCurr_Failure	This fault is usually caused by Loads too large for the inverter. If Off-Grid, the battery discharge Amps are programmed too low. Overloads can result in faults F15, F18, F20, or F26.
F16	GFCI_Failure	Ground fault. Check PV+ or PV- wiring (which must be ungrounded). Exposed PV conductors + rain can also cause this. Check that the neutral line and Ground are not double-bonded (this is common with portable generators).
F17	Tz_PV_OverCurr_Fault	PV HW overcurrent: Do not plug in PV when inverter is already running and the disconnect is ON. Remove PV strings and see if the fault still exists.
F18	HW_Ac_OverCurr_Fault	The Load Output is overloaded (need to reduce loads) or the generator is overloaded a (need to reduce Gen Start A). Wiring Short on the AC Side can also cause this error. Overloads can result in faults F15, F18, F20, or F26.
F20	Tz_Dc_OverCurr_Fault	It is typically caused by DC current from the battery that is too large (ex: 4 Ton AC Unit) or too much PV current (3 or more strings in parallel). Overloads can cause faults F15, F18, F20, or F26.
F22	Tz_EmergStop_Fault	Initiated emergency stop by opening the B/B circuit. Reset the e-stop button (close contacts) to clear the fault.
F24	DC_Insulation_Fault	An exposed PV conductor combined with moisture is faulting (can cause faults F16, F24, and F26).
F25	DC_Feedback_Fault	There is no battery connection to the Inverter and "Activate Battery" is enabled. Disable "Activate Battery" in settings while no battery is connected.
F26	BusUnbalance_Fault	Too much load on one leg (L1 or L2) versus the other leg or DC loads on the AC output when Off-Grid. Grounded PV+/- wire can cause faults F20, F23, or F26.
F29	Parallel_CANBus_Fault	This usually indicates a communication error for parallel systems. Check the cables and MODBUS addresses.
F31	AC_SlaveContactor_Fault	A Soft Start of the large motor failed.
F34	AC_Overload_Fault	AC Overload or load shorted. Reduce heavy loads.
F35	AC_NoUtility_Fault	Grid connection lost.
F37	DCLLC_Soft_Over_Cur	Software DC overcurrent.
F39	DCLLC_Over_Current	Hardware DC overcurrent.
F40	Batt_Over_Current	Batteries exceeded their current discharge limit.
F41	Parallel_System_Stop_Fault	If one system faults in parallel, this normal fault will register on the other units as they disconnect from the grid.
F45	AC_UV_OverVolt_Fault	Grid under voltage causes a disconnect. This will self-reset when the grid stabilizes.
F46	Battery_Backup_Fault	Cannot communicate with other parallel systems. Check Master = 1, Slaves = 2-9, and ethernet are connected.
F47	AC_OverFreq_Fault	Grid over Frequency (common in power outages) causes disconnect. Will self-reset when grid stabilizes.
F48	AC_UnderFreq_Fault	Grid under Frequency (common in power outages) causes a disconnect. Will self-reset when grid stabilizes.

Fault	Description	Common Cause/Remedy
F50	BAT_V_float	Battery voltage reading fault. This can happen if BMS V reading is too different than internal reading. Check external breakers and BMS battery relay status.
F52	DC_VoltHigh_Fault	HV bus V is too high. Reboot the inverter and wait to see if the fault occurs again. Check the PV and Batt V.
F54	BAT2_VoltHigh_Fault	PV may be higher than 500V. Battery voltage should not be above 59V or 63V (depending on the model).
F55	BAT1_VoltHigh_Fault	Batt Voltage on input 1 is too high. Verify the V reading on the inverter screen and with meter. Stop operation, then immediately check with the battery manufacturer.
F56	BAT1_VoltLow_Fault	This fault can occur when batteries are overly discharged, the inverter is Off-Grid and exceeded the programmed batt discharge current by 20%, or Lithium BMS has shut down. If battery settings are incorrect, this can also trigger the fault.
F57	BAT2_VoltLow_Fault	Batt Voltage on input 2 is too low. Check the BMS status and verify readings with a meter and at the screen.
F58	BMS_Communication Fault	The Sol-Ark is programmed to BMS Lithium Battery Mode but cannot communicate with a BMS. BMS_Err_Stop is enabled but cannot communicate with a battery BMS.
F59	BAT_OverCurr_Fault	Excessive load is drawing too much current from the battery. The battery voltage is too low for the inverter to operate.
F60	Gen_Volt_or_Fre_Fault	Generator Voltage or Frequency went outside the allowable range.
F61	Button_Manual_OFF	The parallel "slave" system turned off without turning off the "master."
F63	Arc_Fault	This fault can indicate a poor PV connector or connection, or sometimes a false alarm due to powerful lightning storms.
F64	Heatsink_HighTemp_Fault	Check that the built-in fans are running: the ambient temperature may be too high. Make sure there are proper clearances.

9. Installation Checklist

After the system is operational, complete this form and register at <https://www.Sol-Ark.com/register-your-Sol-Ark/>

Installer/Company: _____ Date: (YYYY-MM-DD) _____

Inverter SN: _____ Gateway _____
SN: _____



Mark for all that apply

Type of system (all that apply):

- | | | | |
|---|--|-----------------------------------|---|
| <input type="checkbox"/> Grid-Tied only | <input type="checkbox"/> Grid-Tied with battery backup | <input type="checkbox"/> Off-Grid | <input type="checkbox"/> Parallel system: # inverters |
|---|--|-----------------------------------|---|

Integrated components (all that apply):

- | | | | |
|---|---|--|------------------------------------|
| <input type="checkbox"/> Utility grid | <input type="checkbox"/> DC solar panels | <input type="checkbox"/> AC coupled solar panels | <input type="checkbox"/> Generator |
| <input type="checkbox"/> "LOAD" installed service panel | <input type="checkbox"/> "GRID" installed service panel | <input type="checkbox"/> GEN installed service panel | <input type="checkbox"/> Batteries |
| <input type="checkbox"/> Lead-Acid batteries | <input type="checkbox"/> Wind Turbine | | |

⚠ Sol-Ark expressly disclaims any responsibility for performance issues arising from improper installation. Installers and users are solely responsible for following proper installation procedures outlined in provided documentation. Sol-Ark disclaims any liability for changes in the installation that might result in electrical malfunctions or any other issues related to the Sol-Ark product.

! Circle **N/A (Not Applicable)** if the verification step is not relevant to the system or does not apply to the integrated components.

A wiring diagram of the installation was sent to Sol-Ark for verification	<input type="checkbox"/> Y <input type="checkbox"/> N
Setup for remote system monitoring through Wi-Fi / Ethernet is completed. Gateway SN: _____	<input type="checkbox"/> Y <input type="checkbox"/> N
The inverter is installed in a location where the LCD screen is always protected from direct sunlight	<input type="checkbox"/>
The inverter has the minimum specified vertical and lateral clearance for proper heat dissipation	<input type="checkbox"/>
The maximum DC input voltage does not surpass 1,000V _{DC}	<input type="checkbox"/>
The HV Battery bank voltage does not surpass 700V _{DC}	<input type="checkbox"/>
All battery conductors are properly connected and secured to the (+, -) terminals of the inverter	<input type="checkbox"/> N/A
Battery communication was successfully established	<input type="checkbox"/> N/A
All Battery Setup parameters are programmed according to battery manufacturer specifications	<input type="checkbox"/> N/A
The Sol-Ark properly generates power from the solar panels to charge the batteries	<input type="checkbox"/> N/A
Grid / Generator is properly connected to the Sol-Ark and the phase sequence was verified	<input type="checkbox"/> N/A
<input checked="" type="checkbox"/> "Grid / Gen Charge" settings are programmed correctly. Grid / Generator adequately charge the batteries	<input type="checkbox"/> N/A
For Off-Grid systems: The mode "General Standard" is programmed and the V & f ranges are increased	<input type="checkbox"/> N/A
When <input checked="" type="checkbox"/> Grid Sell is enabled, the Sol-Ark sells power back to the grid (negative HM measurements for L1, L2, L3)	<input type="checkbox"/> N/A
CT sensors are correctly installed on Grid / Generator lines	<input type="checkbox"/> N/A
Only when <input checked="" type="checkbox"/> Limited Power to Home is enabled, the Sol-Ark matches total load demand (Meter Zero)	<input type="checkbox"/> N/A
Disconnect the grid: during Off-Grid operation, the inverter properly supplies "LOAD" demand for PV and batteries	<input type="checkbox"/> N/A
Disconnect the grid AND solar panels: during Off-Grid operation, the inverter properly draws power from batteries	<input type="checkbox"/> N/A

Installer name and signature

Customer name and signature

Date

10. Inverter UI Screens

The user interface (UI) screens on the following pages show the version of the Sol-Ark inverter firmware as of the Effective Date. Sol-Ark continually improves its products through firmware updates, which may alter the appearance, layout, or functionality of the UI screens. Sol-Ark does not warranty performance if you fail to update or use the most recent version of Sol-Ark software.

10.1 Main Menu

✓

Solar Today=0.0 KWH

Total=0.0 KWH

⚙️

60.00
KW

0.00
KW

0.00
KW

100%
0.00
KW

Solar	Grid	INV	USP LD	Batt
0W	0W	0W	0W	0W
0V/0.5A	0.0Hz	60.0Hz	L1: 0V	0.0V/ 0%
M1: 0W	L1: 0V	L1: 0V	L2: 0V	0.00A
364V/0.0A	L2: 0V	L2: 0V	L3: 0V	0.0C
M2: 0W	L3: 0V	L3: 0V	L1: 0W	0.00V/ 0%
0V/0.1A	HM1: 0W	L1: 0A	L2: 0W	0.00A
M3: 0W	HM2: 0W	L2: 0A	L3: 0W	0.0C
362V/0.8A	HM3: 0W	L3: 0A	Gen 60.0Hz 0W	
M4: 0W	LD1: 0W	L1: 0W	L1: 0W	L1: 0W
TEMP		LD2: 0W	L2: 0W	L2: 0W
AC:19.4C	LD3: 0W	L3: 0W	L3: 0W	L3: 0W

System Alarms 1/25/2021 03:05:27 PM Mon.

Alarms Code	Occurred
F13 Grid_Mode_changed	2021-01-13 11:22
F13 Grid_Mode_changed	2021-01-13 11:20

System Setup 10/14/2022 03:05:27 PM Fri.

Basic Setup

System Alarms

Battery Setup

Li-Batt Info

Limiter

Grid Setup

Sol-Ark 60K-3P-HV
- ID: #####
- COMM: ####
- MCU: Ver####

0.00 V	0.00 A	0.0 C	0%	0 Ah
0.0 V	0.0 V	0A	0A	0x00 0x00

Only w/ BMS Lithium Mode

1. 0.00 V	0.00 A	0.0 C	0.0%	0.0V	0.0A	0 0 0
2. 0.00 V	0.00 A	0.0 C	0.0%	0.0V	0.0A	0 0 0
3. 0.00 V	0.00 A	0.0 C	0.0%	0.0V	0.0A	0 0 0
4. 0.00 V	0.00 A	0.0 C	0.0%	0.0V	0.0A	0 0 0
5. 0.00 V	0.00 A	0.0 C	0.0%	0.0V	0.0A	0 0 0
6. 0.00 V	0.00 A	0.0 C	0.0%	0.0V	0.0A	0 0 0
7. 0.00 V	0.00 A	0.0 C	0.0%	0.0V	0.0A	0 0 0
8. 0.00 V	0.00 A	0.0 C	0.0%	0.0V	0.0A	0 0 0
9. 0.00 V	0.00 A	0.0 C	0.0%	0.0V	0.0A	0 0 0
10. 0.00 V	0.00 A	0.0 C	0.0%	0.0V	0.0A	0 0 0
11. 0.00 V	0.00 A	0.0 C	0.0%	0.0V	0.0A	0 0 0
12. 0.00 V	0.00 A	0.0 C	0.0%	0.0V	0.0A	0 0 0
13. 0.00 V	0.00 A	0.0 C	0.0%	0.0V	0.0A	0 0 0

10.2 Basic Setup

Basic Setup

Display | Time | **Advanced** | Factory Reset | Parallel

Brightness Beep

Auto Dim 600S

CANCEL OK

Basic Setup

Display | Time | **Advanced** | Factory Reset | Parallel

AM/PM Year 2021 Month 10 Day 26

Time Sync PM Hour 03 Minute 04 Second 15

Seasons

Start M-D	Season1	Season 2	Season 3
1 - 1	4 - 1	8 - 1	12 - 1
End M-D	4 - 1	8 - 1	12 - 1

CANCEL OK

Basic Setup

Display | Time | **Advanced** | Factory Reset | Parallel

Solar Arc Fault ON Clear Arc_Fault

ARC parameters
030000
045000
000400
000050
000390
000055
238094

Gen Limit Power 60000W

Load Limit Power 60000W

Grid peak-shaving Power 60000W

Auto detect Home Limit Sensors CT ratio 6000

UPS Time 0ms

CANCEL OK

Basic Setup

Display | Time | **Advanced** | Factory Reset | Parallel

Factory Reset System selfcheck

Lock out all changes Test Mode

Lock Grid Charging & Limited

CANCEL OK

Basic Setup

Display | Time | **Advanced** | Factory Reset | Parallel

Parallel Master Modbus SN 00 Slave

Meter > Grid Meter > Load

Meter Select No Meter Meter Select No Meter

CANCEL OK

10.3 Batt Setup

Batt Setup

Batt | Charge | Discharge | Smart Load

Batt capacity: 200Ah BMS Lithium Batt 01

Max A charge: 50A Use Batt V charged

Max A discharge: 50A No Battery

Parallel bat1&bat2

CANCEL OK

Batt Setup

Batt | Charge | Discharge | Smart Load

StartV: 490.0V 490.0V Float V: 552.0V

Start%: 30% 30%

A: 40A 40A

Gen Charge Grid Charge

Gen Force CANCEL OK

Batt Setup

Batt | Charge | Discharge | Smart Load

Shutdown: 170.0V 10%

Low Batt: 165.0V 20%

Restart: 180.0V 50%

Batt Empty V: 160.0V BMS_Err_Stop

CANCEL OK

Batt Setup

Batt | Charge | Discharge | Smart Load

Use gen input as load output For AC Coupled Input to Gen

On Grid always on High Frz: 65.00Hz

Smart Load OFF Batt: 510.0V 95%

Smart Load ON Batt: 540.0V 100%

CANCEL OK

10.4 Limiter

Grid Param

Limiter | Other

Grid Sell 60000

Time	Power(W)	Batt	Charge	Sell
01:00AM	2000	50%		
05:00AM	2000	50%		
09:00AM	2000	100%		
01:00PM	2000	100%		
05:00PM	2000	50%		
09:00PM	2000	50%		

Limited Power to Load

Time of Use Setup

CANCEL OK

Grid Param

Time of Use Setup

Mon. Tues. Wed. Thur.

Fri. Sat. Sun.

Season1 Season2 Season3

CANCEL OK

Grid Param

Limiter | Other

GEN connect to Grid Input

Zero Export Power: 10W

Batt First Load First

CANCEL OK

10.5 Grid Setup

Grid Param

Grid Selection	Connect	IP	F(W)	V(W)/V(Q)	P(Q)/P(F)
Grid Mode: 1/3 UL1741 & IEEE1547					
Grid Frequency: 50Hz 60Hz					
Grid Reconnect Time: 300s					
Fixed PF: <input type="checkbox"/>					
Fixed Q: <input type="checkbox"/>					
Q_Response_T: 5.0S					
Grid Level: LN:277V/LL:480V(AC)					
Phase Type: 0/240/120					
CANCEL		OK			

Grid Param

Grid Selection	Connect	IP	F(W)	V(W)/V(Q)	P(Q)/P(F)
Reconnect					
Grid Vol High: 504.0V					
Grid Vol Low: 422.4V					
Grid Hz High: 60.1Hz					
Grid Hz Low: 59.5Hz					
Reconnect Ramp rate: 300s					
Normal connect					
Grid Vol High: 576.0V					
Grid Vol Low: 240.0V					
Grid Hz High: 65.0Hz					
Grid Hz Low: 50.0Hz					
Normal Ramp rate: 300s					
CANCEL		OK			

Grid Param

Grid selection	Connect	IP	F(W)	V(W)/V(Q)	P(Q)/P(F)
Over Voltage U>(10 min. running mean) 239.2V					
HV3: 576.0V					
HV2: 576.0V -- 0.16s					
HV1: 528.0V -- 13.00s					
LV1: 422.4V -- 21.00s					
LV2: 240.0V -- 2.00s					
LV3: 240.0V					
HF3: 65.00Hz					
HF2: 65.00Hz -- 0.16s					
HF1: 63.00Hz -- 180.00s					
LF1: 57.00Hz -- 180.00s					
LF2: 50.00Hz -- 0.16s					
LF3: 50.00Hz					
CANCEL		OK			

Grid Param

Grid selection	Connect	IP	F(W)	V(W)/V(Q)	P(Q)/P(F)
Over frequency					
Start freq F: 60.04Hz					
Start delay: 0.50s					
Droop F: 42%PE/Hz					
Stop freq F: 60.04Hz					
Stop delay: 0.50s					
Under frequency					
Start freq F>: 59.96Hz					
Start delay F>: 0.50s					
Droop F>: 42%PE/Hz					
Stop freq F>: 59.96Hz					
Stop delay F>: 0.50s					
CANCEL		OK			

Grid Param

Grid selection	Connect	IP	F(W)	V(W)/V(Q)	P(Q)/P(F)
<input checked="" type="checkbox"/> V(W)					
<input checked="" type="checkbox"/> V(Q)					
Response_T: 5S					
V1:106.0%	P1:100%				
V2:110.0%	P2:0%				
V3:110.0%	P3:0%				
V4:110.0%	P4:0%				
Lin:5.0%	Lout:20.0%				
V1:92.0%	Q1:44%				
V2:98.0%	Q2:0%				
V3:100.0%	Q3:0%				
V4:106.0%	Q4:44%				
CANCEL		OK			

Grid Param

Grid selection	Connect	IP	F(W)	V(W)/V(Q)	P(Q)/P(F)
<input type="checkbox"/> P(Q)					
<input type="checkbox"/> P(F)					
P1:20%	Q1:100%				
P2:50%	Q2:100%				
P3:100%	Q3:100%				
P4:100%	Q4:100%				
Lin:5.0%	Lout:100.0%				
P1:50.0%	F1:1.000				
P2:100.0%	F2:0.800				
P3:100.0%	F3:0.800				
P4:100.0%	F4:0.800				
CANCEL		OK			

