



BATTERY INTEGRATION GUIDE

LOW VOLTAGE 48V – RESIDENTIAL

REVISION 7

Effective Date: March 24, 2026

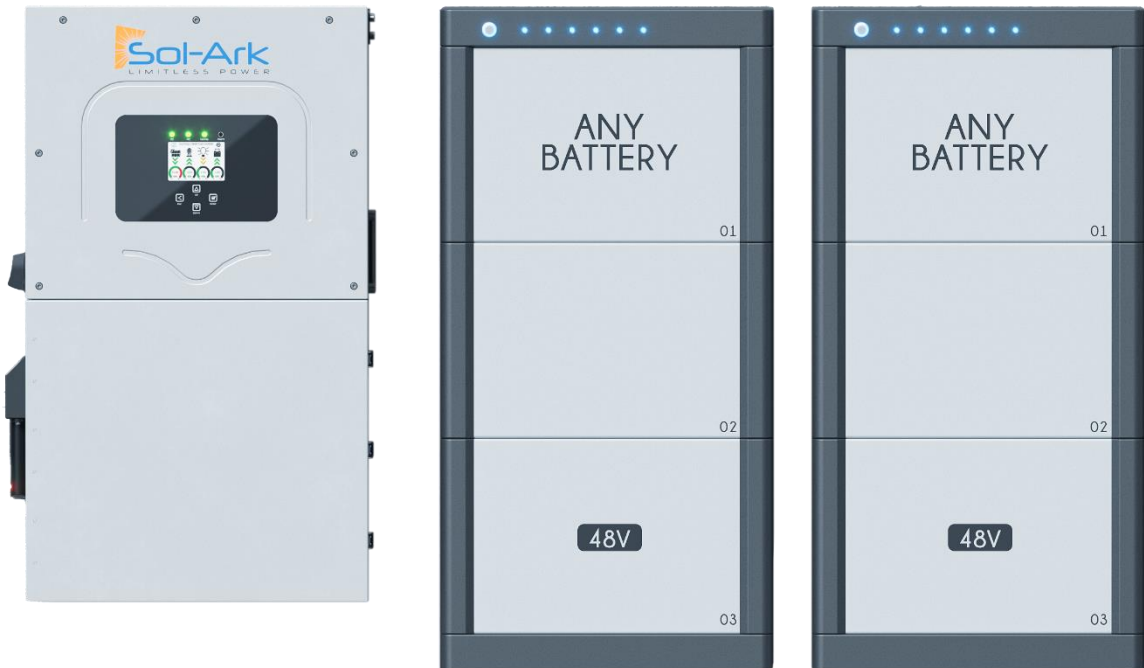



About this Guide

This Battery Integration Guide provides general assistance with integrating third-party batteries and Sol-Ark manufactured hybrid inverters. It is not intended to substitute for, or to replace, the guidance or services of trained installers, engineers, or other specialists who are responsible for system installation, design, testing, and performance. It should not replace or modify any of the technical, support, or other information made available by the Battery manufacturer, including information related to safety and performance established by the Battery manufacturer.

Consult with the Battery manufacturer and those responsible for installation, testing, and system performance before undertaking any of the integration steps in this Guide. In-depth configurations, step-by-step instructions, troubleshooting, and verification of operational parameters are not addressed in this Guide and are outside its scope.

Battery technology is constantly evolving, so new features, requirements, or compatibility considerations may arise. Please stay informed about the latest developments and recommendations from both Sol-Ark and the battery manufacturer.

Sol-Ark does not offer technical support for battery communications with battery models not listed in this Guide.

The warranty does not cover damage caused by any battery that is not specifically listed in Sol-Ark's *Low Voltage Battery Integration Guide*, and Sol-Ark hereby disclaims and excludes coverage for damage caused by any battery not included herein.

Please read the full **Disclaimer** on page 43 before proceeding.

This guide is for only **Low-Voltage Hybrid Sol-Ark Inverters**.



Contents

Sol-Ark Inverters in this Guide	1
Latest Firmware	1
About Sol-Ark Storage Partners	2
Certified Storage Partners	2
Proven Storage Partners	2
General Hardware Configuration	3
Sol-Ark 18K.....	3
Sol-Ark Outdoor Inverters: 15K/12K.....	4
Sol-Ark Indoor Inverter: 12K-2P-LV (Legacy).....	5
Sol-Ark Indoor Inverter: 8K (Legacy)	6
CANBus Battery Screen	7
Connecting Batteries	8
Certified Storage Partners.....	8
Briggs&Stratton	9
SimpliPHI™ 6.6 Energy Storage System (ESS)	10
Deka	11
Duration – DD5300 (Low Voltage configuration)	11
Discover Energy Systems	13
Helios ESS.....	13
AES RACKMOUNT 48-48-5120-H	14
Dyness	16
Dyness B4850	16
Dyness PowerBoxPro.....	18
EndurEnergy	20
ESP-5100	20
Homegrid.....	22
Stack'd	22
Liniotech	24
LTN051280A-B-GBP2.....	24



Pylontech	25
Pelio-L-5.12.....	25
US3000C.....	26
Pytes	28
V5	28
V16	29
RENON	30
RENON Xcellent Plus R-XC016161-H-US.....	30
RENON Xtreme LV Series.....	31
Soluna	33
10K PACK LV	33
Volthium Energy	34
51.2-100-R-H.....	34
Proven Storage Partners	36
Fortress	37
eFlex Max	37
EVault Max	38
POWERSYNC	39
LFP3250-LV480100SP.....	39
Storz Power	40
LFP48100-5KWH	40
Storz Battery Modbus/RS-485 Screen	42

Contact Us

+1 (972) 575-8875 ext. 2

Support@Sol-Ark.com

www.Sol-Ark.com



Sol-Ark Inverters in this Guide

This document covers battery integration with these Sol-Ark low-voltage hybrid inverters:

- Sol-Ark 18K (Outdoor)
- Sol-Ark 15K (Outdoor)
- Sol-Ark 12K (Outdoor)
- Sol-Ark 12K (Indoor)
- Sol-Ark 8K (Outdoor)
- Sol-Ark 5K (Outdoor)

Latest Firmware



For reliability of CANbus communication, update to the latest firmware version, with **C 1.4.5.2** or greater.

Sol-Ark seeks to ensure that its hybrid inverters work with batteries supplied by a diverse set of manufacturers within the residential market segment. This Guide lists batteries that have been certified to work with Sol-Ark hybrid inverters as of the Effective Date. If not listed, the battery has not been certified to work with Sol-Ark hybrid inverters, or tested by Sol-Ark, but Sol-Ark inverters are designed to be battery agnostic and can generally function with most 48V batteries.

Homeowners select batteries based on various considerations including pricing, support, warranty, and finances. You may need a battery rated for the outdoors, or one that can withstand an electromagnetic pulse (EMP). Decoupling storage and inverter power lets our customers select the power output and energy storage solution they need.

This guide is divided into two sections, **Certified Storage Partners** and **Proven Storage Partners**.



About Sol-Ark Storage Partners

Certified Storage Partners

These battery manufacturers have a history of installation compatibility with Sol-Ark:

Briggs and Stratton Energy Solutions | Deka by MK Battery | Discover Energy Systems
Dyness | EndurEnergy | Homegrid | Pylontech | Pytes Energy
Renon Power | Soluna | Volthium Energy

- Sol-Ark has tested communications and electrical capability of our respective products.
- Sol-Ark collaborates on critical safety and regulatory requirements to ensure our customers are able to commission and permit our joint solutions.
- Sol-Ark has an agreement to ensure ongoing product compatibility, and to ensure the highest level of product reliability, support, and customer service.
- Partners in this category have at least one battery model that has passed Sol-Ark's testing and certification process.

Note: Even if listed above, Certified Storage Partner batteries may be modified, updated, or otherwise changed by the manufacturer, or performance and other characteristics may change over time. Please check the manufacturer documentation regarding any proposed pairing, installation, or integration of your battery. **Sol-Ark does not guarantee or warranty the performance of any battery or the system into which a battery and inverter may be integrated.**

Proven Storage Partners

These battery manufacturers have a history of battery installations with Sol-Ark inverters:

Fortress | Powersync | Storz Power

- The Proven Storage Partners are well-known suppliers, broadly accessible to installers. These manufacturers provide reputable products and domestic customer support.
- Sol-Ark has tested these specific solutions for compatibility with the documented firmware versions. Any other versions related to the battery solution cannot guarantee the same level of operational reliability as what's documented in this guide.
- Sol-Ark will support the configuration and firmware versions listed in this guide. If any other variations of firmware are present, Sol-Ark cannot guarantee proper operation. We'll accept service calls with basic diagnostic methods for the *Inverter only*. For battery questions, Sol-Ark please contact the respective battery partner for support.



While this Guide lists only those battery companies that have collaborated with Sol-Ark, Sol-Ark inverters have been designed and intended to work with many other batteries.



General Hardware Configuration



The outdoor-rated systems and Sol-Ark 18K inverters have a **Modbus RS-485** port, which is not for battery communications, with the exception of Storz batteries.

Sol-Ark 18K



The 18K inverter communicates with the battery through a single RJ45 port: **Battery CANBus**. It combines the Modbus and CANBus pin configurations.

The diagram shows the communication board inside the 18K wiring area. Note that only the **Battery CANBus** port is used for battery communications. The RJ45 pin configurations for Modbus and CANBus communication are listed below.

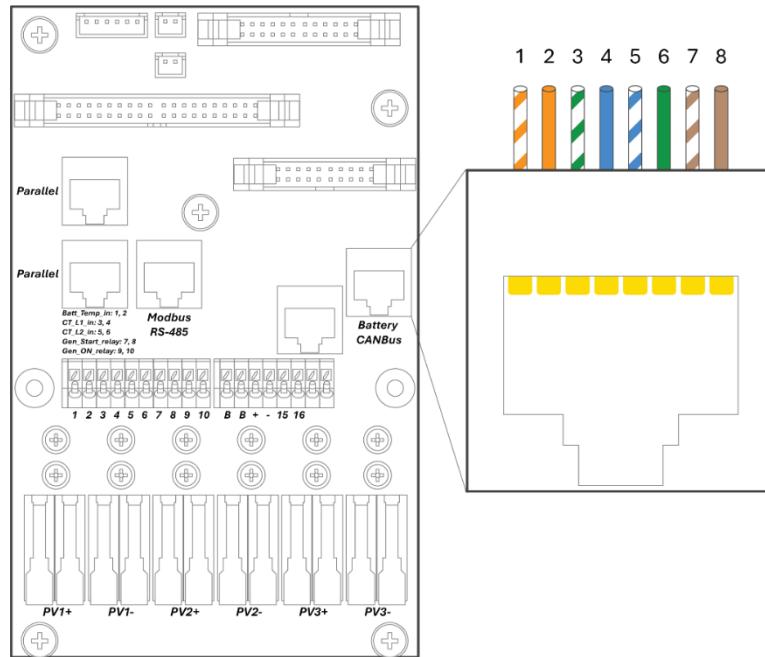

18K-2P-LV CON board and **Battery CANBus** communication port

Pin Configurations of Battery CANBus Port for ModBus and CANBus Protocols—*Storz Only*

Pin	CANBus/ModBus	Pin	CANBus/ModBus
1	TX A+ (either orange or brown)	5	CAN Lo
2	TX B-	6	GND
3	--	7	TX B-
4	CAN Hi	8	TX A+

Notes

- Modbus battery communication is only for Storz batteries listed in this guide.
- Modbus is not recommend for any Battery Communication other than Storz.



Sol-Ark Outdoor Inverters: 15K/12K



The Sol-Ark Outdoor-Rated inverters 15K-2P-LV and 12K-2P-LV communicate with the battery through a single RJ45 port labeled **Battery CANBus**. This port combines the Modbus and CANBus pin configurations shown below.

The diagram shows the communication board inside the wiring area of Sol-Ark inverters. Note that only the **Battery CANBus** port is used for battery communications. The table lists pin configurations for Modbus and CANBus communication of the RJ-45.

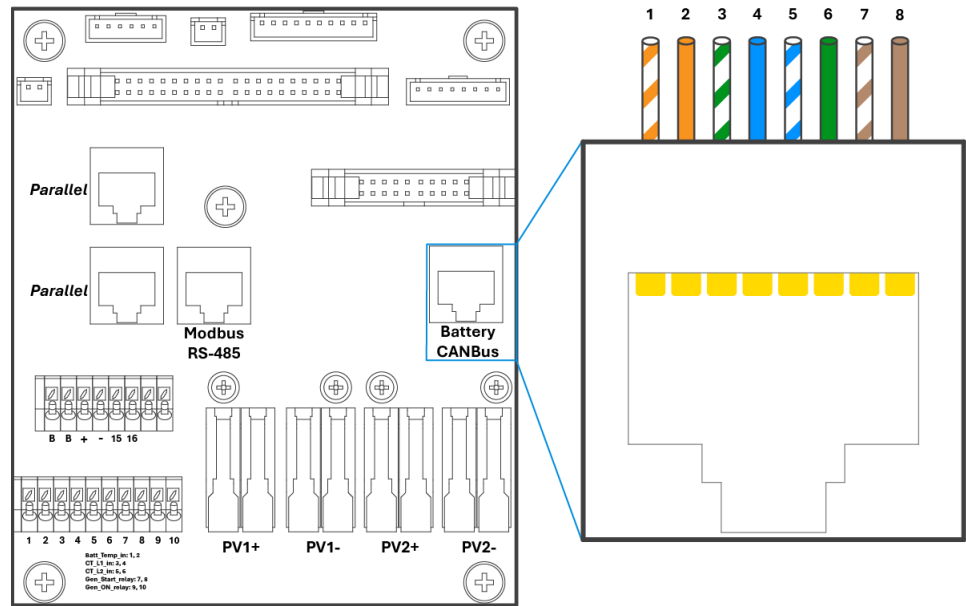

15K/12K CON board and **Battery CANBus** communication port

Pin Configurations of **Battery CANBus** Port for ModBus and CANBus Protocols

Pin	CANBus/Modbus
1	TX A+ (either orange or brown)
2	TX B-
3	--
4	CAN Hi
5	CAN Lo
6	GND
7	TX B-
8	TX A+



Sol-Ark Indoor Inverter: 12K-2P-LV (Legacy)



The Sol-Ark 12K-2P-LV Indoor can communicate through two RJ-45 ports labeled **CAN** and **RS-485**. Battery communication is established through CANBus or Modbus communication protocols using the **CAN** and **RS-485** ports respectively.

The diagram shows the communication board inside the 12K Indoor inverter wiring area. Note that both the **CAN** and **RS-485** ports can be used for battery communications depending on the required protocol. The pin configurations for Modbus and CANBus communications are listed in the table below.

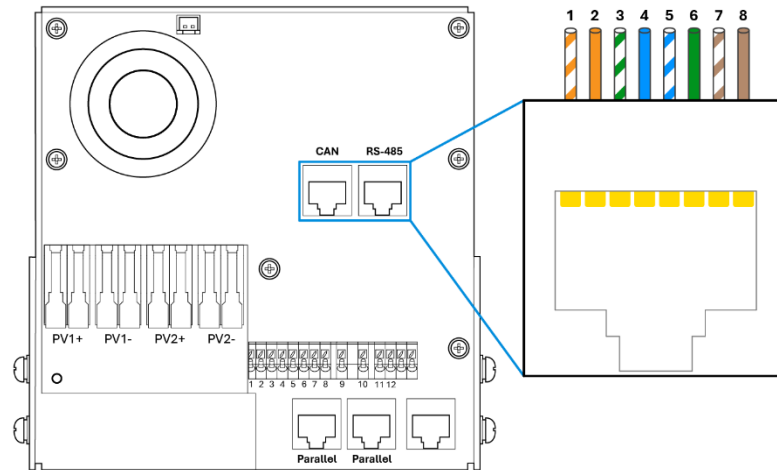

12K Indoor con board and battery **CAN** and **RS-485** communication ports

Pin Configurations of **CAN** and **RS-485** Ports for CANBus and ModBus Protocols

Pin	CAN (CANBus)	RS-485 (Modbus)
1	--	RS-485 B-
2		RS-485 A+
3	GND	--
4	CAN Hi	--
5	CAN Lo	--
6	GND	GND
7	--	RS485 A+
8	--	RS485 B-



Sol-Ark Indoor Inverter: 8K (Legacy)



The Sol-Ark 8K Indoor can communicate through the RJ-45 port labeled **RJ45_CAN**.

The diagram shows the communication board inside the wiring area of the 8K Indoor inverter. The pin configurations for Modbus and CANBus communications are listed in the table below.

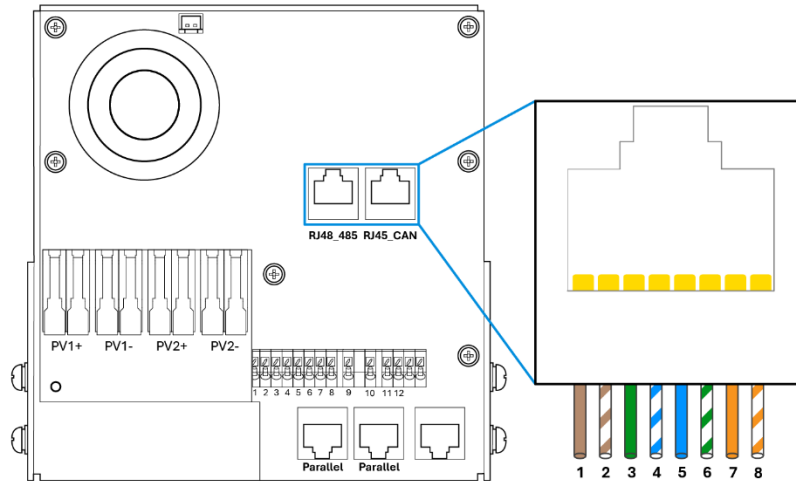

8K Indoor CON board and battery **RJ45_485** and **RJ45_CAN** communication ports

Pin Configuration of **RJ45_CAN** port for ModBus and CANBus protocols

Pin	RJ45_485 (Modbus)	RJ45_CAN (CANBus)
1	RS-485 B-	--
2	RS-485 A+	
3	GND	GND
4	--	CAN Hi
5	--	CAN Lo
6	GND	GND
7	RS485 A+	--
8	RS485 B-	--



CANBus Battery Screen

This is what the **Li Batt Info** screen looks like when communications are enabled for CANBus batteries (**BMS Lithium Batt 00**).

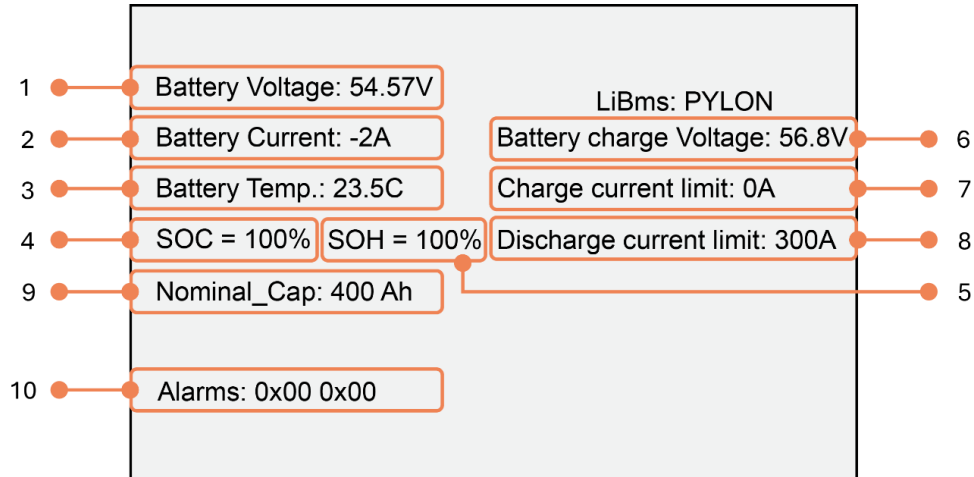

- Battery Voltage:** Real-time voltage measured between the battery terminals.
- Battery Current:** Real-time current flowing into or out of battery's + terminal. (negative/positive sign respectively).
- Battery Temp:** Real-time temperature measured at the BMS.
- SOC:** State of charge remaining in the battery according to the BMS.
- SOH:** State of health of the battery according to the BMS.
- Battery Charge Voltage:** The inverter should charge the battery to the maximum voltage.
- Charge Current Limit:** Maximum current allowed to the battery.
- Discharge Current Limit:** Maximum current allowed out of the battery.
- Nominal Cap:** Amp-hour design capacity of the battery (not used on all batteries).
- Alarms:** Displays any alarm codes from the battery (manufacturer-specific).
- Force Charge Request:** Command sent by the BMS telling the inverter to charge the battery from any available power source regardless of inverter settings. This is not shown in the image, but it's located below the **Alarms** field.



Connecting Batteries

When creating a custom RJ45 cable, use a CAT5/CAT6, also known as ethernet cable. Unless otherwise stated, cut open the cable and cut off the unnecessary wires.

Most custom cables are NOT reversible; therefore, keep track of which end of the custom cable connects to the battery and the Sol-Ark.



If you're crimping new connectors to create a cable, be careful not to over-tighten the crimping tool, as this can recess the connectors and lead to a poor or intermittent connection.

Certified Storage Partners

Sol-Ark has certified that the following battery models work with our inverters as of this guide's Effective Date. This section gives general installation guidelines and links to manufacturer documentation.

Manufacturer ²	Compatible Battery Model	BMS Lith Batt	Custom cable required?
Briggs&Stratton	AmpliPHI 3.8 SimpliPHI™ 6.6 ESS	00	No
Deka	Deka-Duration: DD5300	00	Yes
Discover Energy Systems	Helios ESS AES RACKMOUNT	00	No
Dyness	B4850 Powerbox Pro	00	Yes (outdoor-rated models only)
EndurEnergy	ESP-5100	00	No
Homegrid	Stack'd	00	Yes
Pylontech	Pelio-L-5.12 US3000C	00	Yes
Pytes	V5 V16	00	No
RENON	Xcellent Plus R-XC016161-US Xtreme LV Series	00	No Yes
Soluna	10Pack LV		
Volthium Energy	51.2-100-R-H	00	No

² Trademarks, logos and tradenames of battery manufacturers are used with permission.



Briggs&Stratton

AmpliPHI 3.8 & SimpliPHI™ 6.6 ESS

Follow these instructions for setting up Briggs&Stratton batteries and Sol-Ark inverters.

AmpliPHI 3.8 Communications Installation and Setup Instructions

To ensure optimal performance and safety, consult Briggs & Stratton’s comprehensive documentation for specifications and settings:

[Briggs & Stratton AmpliPHI 3.8 Installation Manual](#)

Custom RJ45 cable

No custom cable is needed.

Battery IDs and connections

1. Connect all batteries using the included RJ45 cables, using the two ports nearest to each other (shown in the green box) to bridge the batteries together.
2. Use the included 120 Ohm terminators on both ends of the resulting chain.

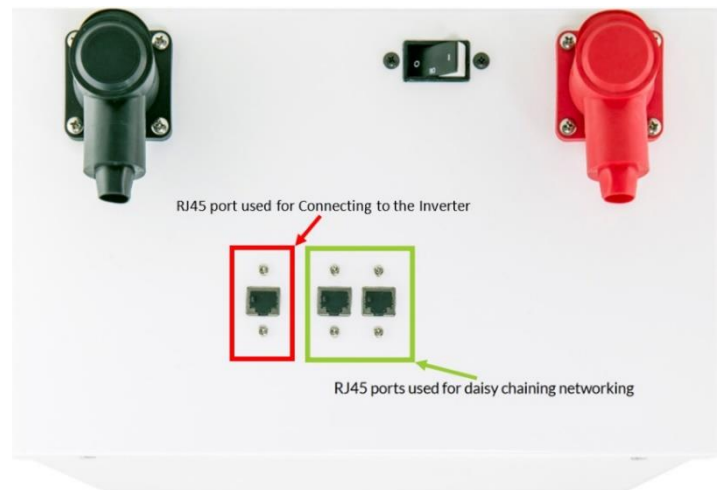

Inverter programming and connections

1. Use the battery from the beginning or the end of the chain. Connect an RJ45 cable from the separate **RJ45** port (shown in the red box above):

Indoor-rated inverters

- You may use an off-the-shelf ethernet cable. No custom cable is needed.
- Connect to the CAN port.

Outdoor-rated inverters

- You may use an off-the-shelf ethernet cable. No custom cable is needed.
- Connect to the **Battery CANBus** port.

2. Program the inverter with this battery’s appropriate charge/discharge settings.
3. Enable **BMS Lithium Batt** and set its value to **00**.
4. (Optional) Turn on **BMS_Err_Stop** if you if you want the system to fault on loss of battery communication.



SimpliPhi™ 6.6 Energy Storage System (ESS)

To ensure optimal performance and safety, consult Briggs & Stratton’s comprehensive documentation for specifications and settings:

[Briggs & Stratton SimpliPhi 6.6 Installation Manual](#)

AmpliPhi 3.8 Communications Installation and Setup Instructions

Single and Multi-Stack Installation

1. Connect an RJ45 cable from the **CAN** port on the battery controller (in purple box below) to the 6.6/Sol-Ark crossover cable, then connect it to the **CAN** port in the Sol-Ark wiring compartment.
2. *To install a single-stack battery system:*
Connect an RJ45 cable from the **RS485** port on the battery controller (in green box below) to the EnergyTrak gateway **CAN** terminal.
OR
To install a multi-stack battery system:
Connect an RJ45 cable from the **RS485** port on the battery controller (in green box below) to the **CAN** port on the next battery. This will connect the RJ45 to the 3-position terminal block included with the gateway.
3. **Note:** If more than 2 stacks are in the system, follow the daisy chain method above, and connect the last battery in the stack to the EnergyTrak gateway.
4. Program the inverter with the appropriate charge/discharge settings for the battery.
5. In the inverter’s **Batt Setup** menu, select **Enable BMS Lithium Batt**, set the value to **00**, and then select **Activate Battery**.

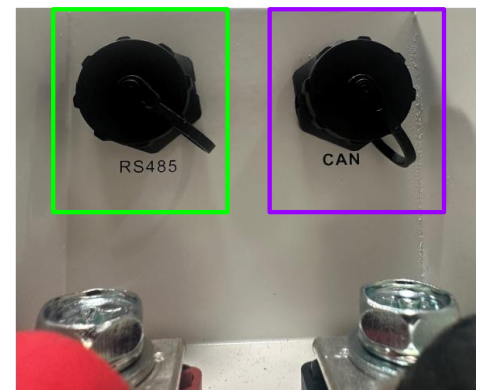
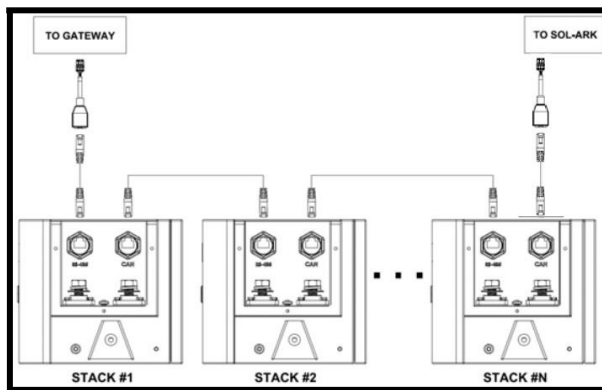
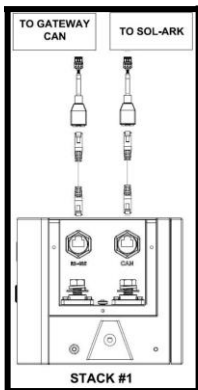



Deka

Duration – DD5300 (Low Voltage configuration)

Follow these instructions for setting up Deka batteries and Sol-Ark inverters.

To ensure optimal performance and safety, consult Deka’s comprehensive documentation for specifications and settings:

[Deka documentation](#)



Communications with this battery requires a custom cable.

- Make sure that you are not wiring to the High Voltage connection terminals of the Deka-DD5300 battery.
- See the Installation & Operation (I&O) manual of the battery manufacturer and verify the proper communications configuration of CANBus connections and dip switch settings.

Communications Installation and Setup Instructions

Custom RJ45 cable

1. Create a custom RJ45 cable that connects battery port pins 1 (white-orange), 2 (solid orange), and 3 (white-green) to inverter port pins 4, 5, and 2 (indoor-rated models) or 6 (outdoor-rated models).

Battery-inverter communication connections

Wire color	Battery (CAN-A port)	Inverter port
White-orange	1	4
Solid orange	2	5
White-green	3	2 (indoor only) or 6 (outdoor only)

Battery IDs and connections

1. Turn on the mechanical POWER SWITCH to enable the BMS on all battery modules.
2. Press and hold the RUN button for 2 seconds only on the “master” battery module, and allow other modules to turn themselves on automatically.

After the battery modules start, the LED status indicator should turn solid green.

Inverter programming and connections

1. Connect the cable to the **CAN-A** port on the Deka-DD5300 and the **Battery CANBus** port (outdoor-rated models) or the **CAN** port (indoor-rated models) on the Sol-Ark.
2. Program the inverter with this battery's appropriate charge/discharge settings.
3. Enable **BMS Lithium Batt** and set its value to **00**.
4. (Optional) Turn on **BMS_Err_Stop** if you want the system to fault on the loss of battery communication.

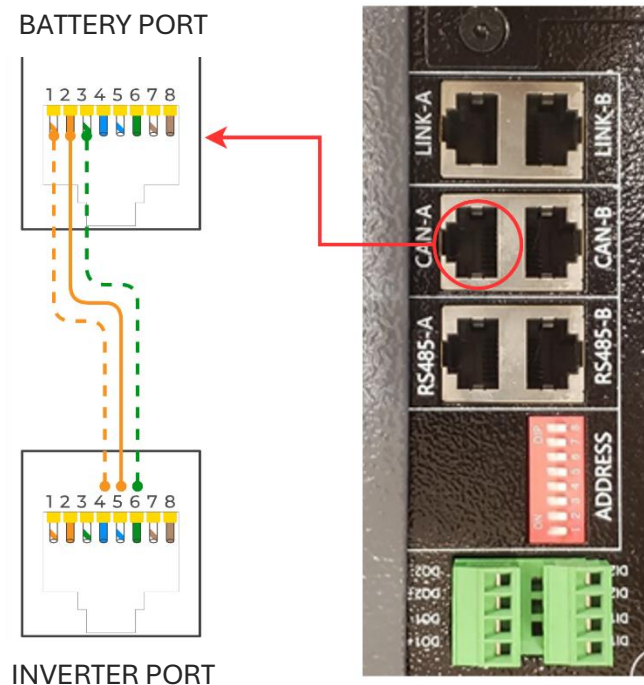



Discover Energy Systems

This section gives instructions for setting up Discover Helios ESS | AES RACKMOUNT 48-48-5120-H batteries with Sol-Ark inverters.

Helios ESS

Communications Installation and Setup Instructions

Follow these instructions for setting up Helios ESS battery and Sol-Ark inverters.

To ensure optimal performance and safety, consult Discover Energy Systems' comprehensive documentation for specifications and settings:

[Helios ESS Documentation](#)

Custom RJ45 cable

- **Outdoor units:** No custom cable is needed.
- **Legacy (Indoor) units:** Use the following configuration:

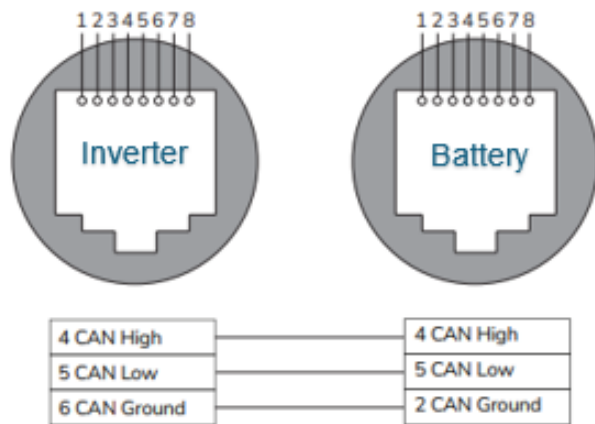

Battery IDs and connections

1. If parallel, connect all batteries using the included CAT 6 cables. Connect the CAT 6 cable from port **COM3** or **COM4** on the first battery to port **COM3** or **COM4** on the next battery. Continue this process, connecting **COM3/COM4** of each battery to **COM3/COM4** on the next, until all batteries are bridged together.
2. Insert the terminal resistor to port **COM4** on the last battery, even if you're using only one battery.

Inverter programming and connections

1. Connect the comm cable provided by Discover, or a CAT 6 higher cable, from the **COM2** port on the Helios ESS to the inverter's **CAN** communication port.
2. Program the inverter with this battery's appropriate charge/discharge settings.
3. Enable **BMS Lithium Batt** and set its value to **00**.
4. (Optional) Turn on **BMS_Err_Stop** if you want the system to fault on loss of battery communication.

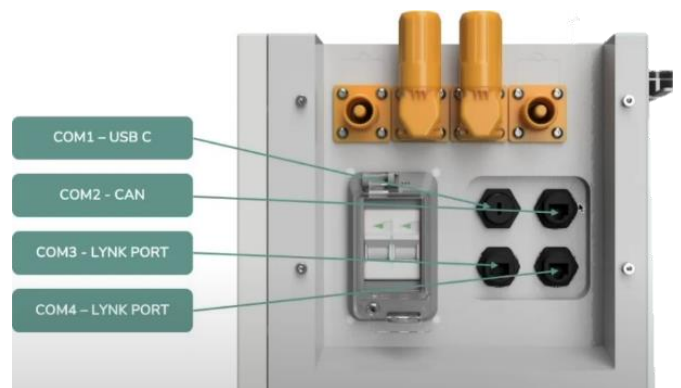



AES RACKMOUNT 48-48-5120-H

Communications Installation and Setup Instructions

To ensure optimal performance and safety, consult Discover Energy Systems’ comprehensive documentation for specifications and settings:

[Discover – AES RACKMOUNT documentation](#) [Discover- LYNK documentation](#)



You need the Discover Lynk device to adapt the battery’s AEBus to CANBus for use with the Sol-Ark inverter. The Lynk requires the proper adapter for the Sol-Ark’s pin configuration (Part number 950-0016-SLRK).



Communication with this battery requires a custom cable (outdoor-rated models only).

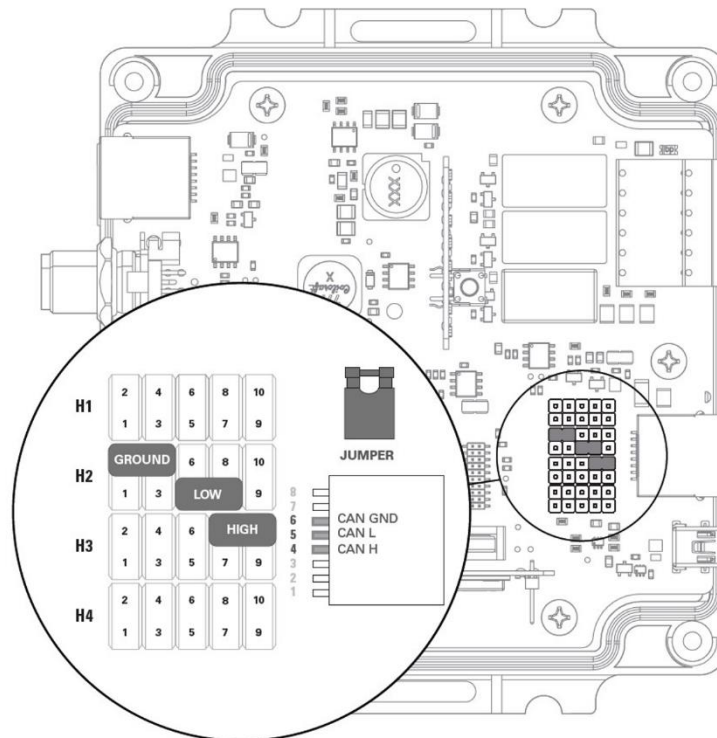

Sol-Ark Outdoor CAN Pin Assignment

Custom RJ45 cable (outdoor-rated inverters only)

No custom cable is needed.



Battery IDs and connections

1. Configure the proper pin assignments of the LYNK II header board for Sol-Ark per the manufacturer's manual.
2. Daisy-chain all modules (if in parallel) together using CAT5e or higher cables between LYNK ports.
3. Connect the LYNK port of a battery at one end of the chain to the LYNK port of the LYNK II.
4. If using the SLIMLINE enclosure, follow the manufacturer instructions for connecting the LYNK ports and the LYNK II.
5. Download and use the LYNK ACCESS software from the Discover Battery website to configure the LYNK II with the pre-configured Sol-Ark protocol.

Inverter programming and connections

1. Connect the cable between the LYNK II **CAN** port and the inverter's **Battery CANBus** port (outdoor only).
2. Power on the battery stack by first switching the breaker to the ON (closed) position, then briefly pressing the Power button to the ON position. If in parallel, turn on the Power Button first, then switch the breakers to the ON position.
3. If using the SLIMLINE enclosure, follow the manufacturer instructions for turning on the battery stack.
4. Program the inverter with this battery's appropriate charge/discharge settings.
5. Enable **BMS Lithium Batt** and set its value to **00**.
6. (Optional) Turn on **BMS_Err_Stop** if you if you want the system to fault on loss of battery communication.



Dyness

Follow these instructions for setting up Dyness batteries and Sol-Ark inverters.

To ensure optimal performance and safety, consult Dyness' comprehensive documentation for specifications and settings:

[Dyness documentation](#)



Communications with this battery requires a custom cable (outdoor-rated models only)

Dyness B4850

Communications Installation and Setup Instructions

Custom RJ45 cable (outdoor-rated inverters only)

1. Create a custom RJ45 cable that connects battery port pins 4 (solid blue), 5 (white-blue), and 2 (solid orange) to inverter port pins 4, 5, and 2 or 6, respectively.

Battery-inverter communication connections

Wire color	Battery (CAN-OUT) port	Inverter port
Solid blue	4	4
White-blue	5	5
Solid orange	2	2 or 6

Battery IDs and connections

1. Check the correct battery interconnection and connect to the inverter as specified in the Dyness user manual.
2. Set the switch in position 3 on the DIP selection switches to the **ON** position for the battery connected to the inverter.

Inverter programming and connections

1. Use the appropriate RJ45 cable to connect one of the batteries to the inverter:
Indoor-rated inverters
 - You may use an off-the-shelf ethernet cable. No custom cable is needed.
 - Connect to the CAN port.Outdoor-rated inverters
 - Use the custom cable described in the beginning of these instructions.
 - Connect to the **Battery CANBus** port.
2. Program the inverter with this battery's appropriate charge/discharge settings.
3. Enable **BMS Lithium Batt** and set its value to **00**.
4. (Optional) Turn on **BMS_Err_Stop** if you if you want the system to fault on loss of battery communication.

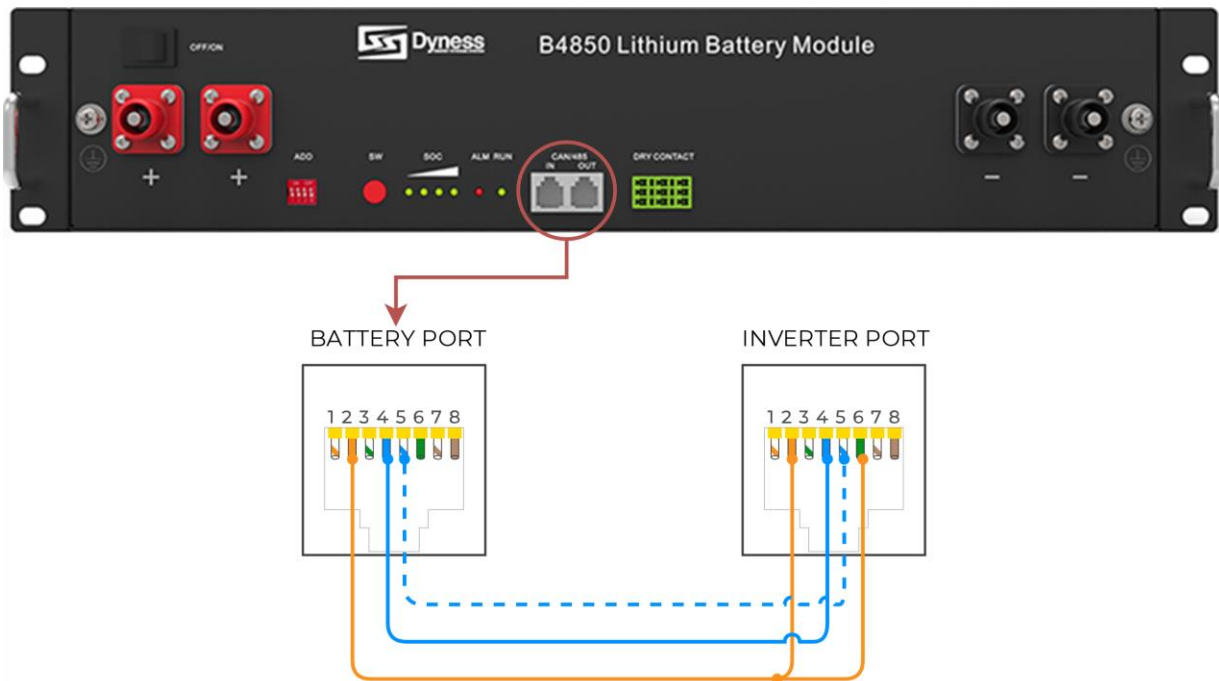

Dyness PowerBoxPro

Communications Installation and Setup Instructions

Custom RJ45 cable (outdoor-rated inverters only)

Create a custom RJ45 cable that connects battery port pins 4 (solid blue) and 5 (white-blue) to inverter port pins 4 and 5, respectively.

Battery-inverter communication connections

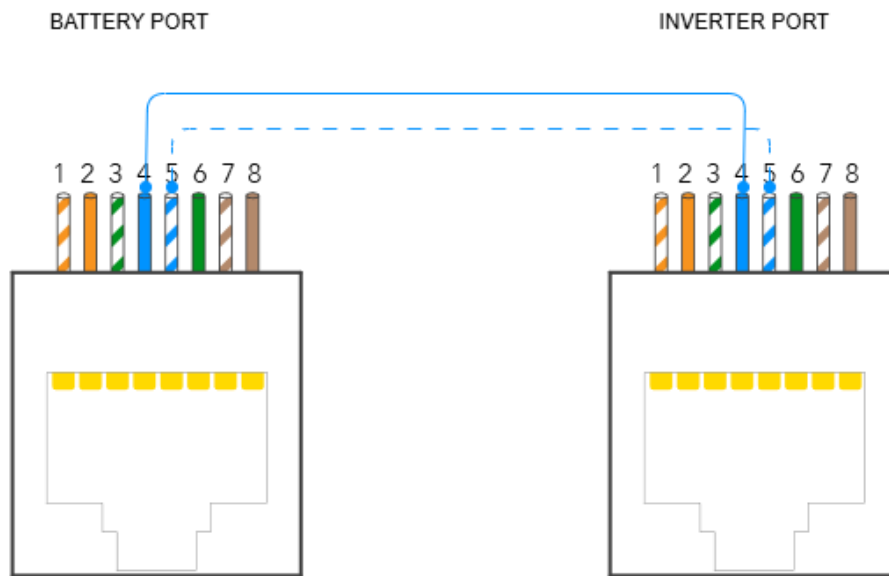

Wire color	Battery (CAN-OUT) port	Inverter port
Solid blue	4	4
White-blue	5	5

Battery IDs and connections

1. Check the correct battery interconnection and connect to the inverter as specified in the Dyness user manual.
2. Set the switch in position **3** on the DIP selection switches to the **ON** position for the battery master module.

Inverter programming and connections

1. Use the appropriate RJ45 cable to connect one of the batteries to the inverter:
Indoor-rated inverters
 - You can use an off-the-shelf ethernet cable. No custom cable is needed.
 - Connect to the CAN port.Outdoor-rated inverters
 - Use the custom cable described at the beginning of these instructions.
 - Connect to the **Battery CANBus** port
2. Program the inverter with this battery's appropriate charge/discharge settings.
3. Enable **BMS Lithium Batt** and set its value to **00**.
4. (Optional) Turn on **BMS_Err_Stop** if you if you want the system to fault on loss of battery communication.

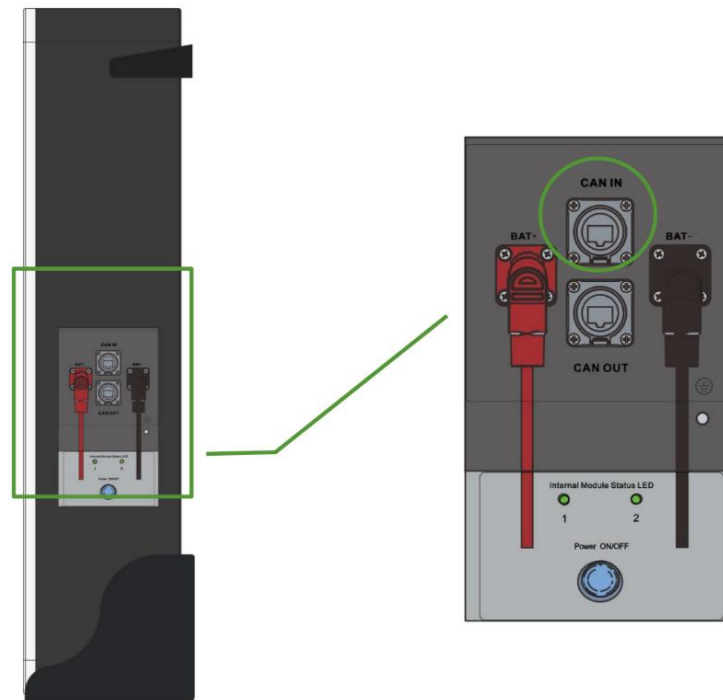



EndurEnergy Systems, Inc.

EndurEnergy

ESP-5100

Follow these instructions for setting up EndurEnergy batteries and Sol-Ark inverters.

To ensure optimal performance and safety, consult EndurEnergy Systems' comprehensive documentation for specifications and settings:

[EndurEnergy documentation](#)

Communications Installation and Setup Instructions

Custom RJ45 cable

No custom cable is needed.

Battery IDs and connections

1. Connect all EndurEnergy ESP-5100 batteries together with the provided RJ45 cable using **M/S** ports. (Can use up to 8 batteries in 48V low voltage configuration)
2. Set all the dip switches according to the battery manual and double-check all dip switches on all batteries in the battery bank.

Inverter programming and connections

1. Connect a standard CAT5/6 cable to the **Inverter** port on the ESP-5100 Master battery, and the **Battery CANBus** port (or the **CAN** port for indoor-only models) on the Sol-Ark.
2. Program the inverter with the appropriate charge/discharge settings according to the specific battery manual and cable arrangement.
3. Enable **BMS Lithium Batt** and set its value to **00**.
4. (Optional) Turn on **BMS_Err_Stop** if you want the system to fault on the loss of battery communication.

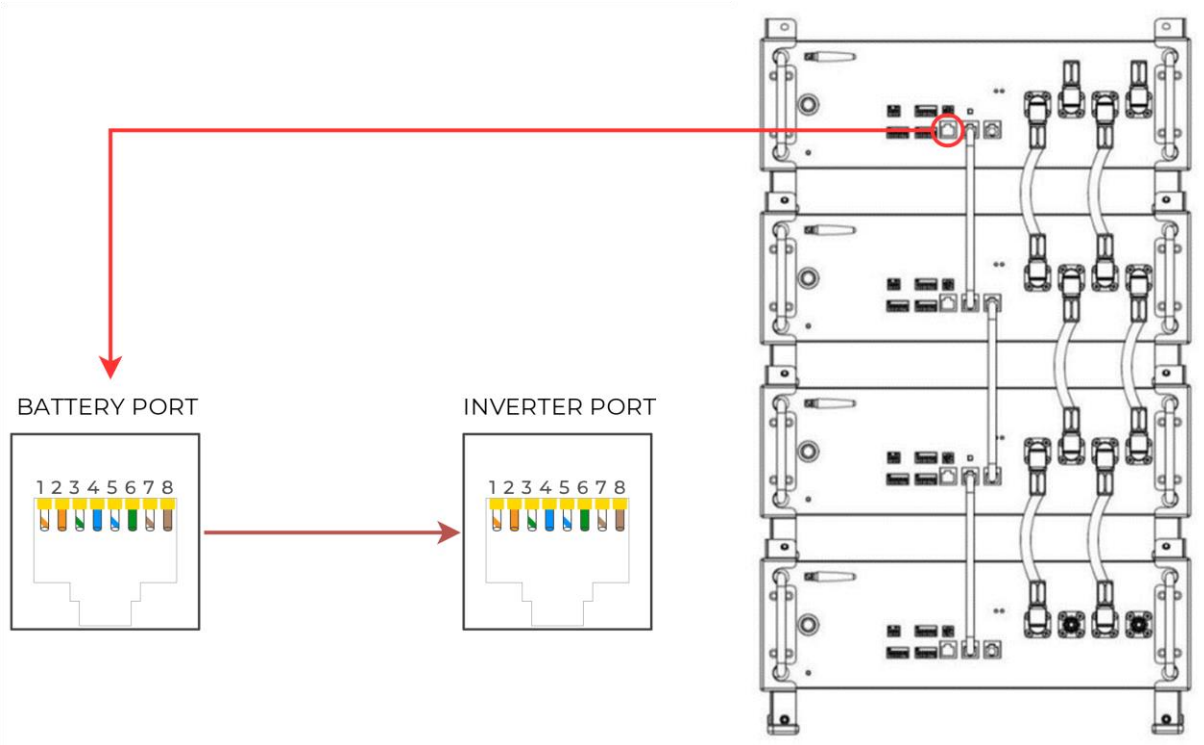



Homegrid

Stack'd

Follow these instructions for setting up Homegrid batteries and Sol-Ark inverters.

To ensure optimal performance and safety, consult Homegrid's comprehensive documentation for specifications and settings:

[Homegrid Stack'd documentation](#)



You need a custom RJ45 cable for this setup.

Communications Installation and Setup Instructions

Custom RJ45 cable

1. Create a custom cable that connects pins 7 and 8 ONLY (white-brown and solid brown) to the battery.
2. Pin 7 (white-brown) connects to pin 4 on the inverter.
3. Pin 8 (solid-brown) connects to pin 5 on the inverter.

Battery-inverter communication connections

Wire color	Battery (CAN) port	Inverter port
White-brown	7	4
Solid brown	8	5

Battery IDs and connections

1. Set the DIP switches on each battery according to the manufacturer's manual.
2. Connect all top modules (if in parallel) together with RJ45 cable between their **Link A** and **Link B** ports. It does not matter which port is connected to which.
3. Power on the battery units by turning on each module from the bottom to the top, followed by that stack's top module.

Inverter programming and connections

1. Connect the cable between the master battery's top module and the inverter's **Battery CANBus** (outdoor-rated models) or **CAN** (indoor-rated models) port.
2. Program the inverter with this battery's appropriate charge/discharge settings.
3. Enable **BMS Lithium Batt** and set this value to **00**.
4. (Optional) Turn on **BMS_Err_Stop** if you want the system to fault on loss of battery communication.
5. If communication still needs to be established, contact HomeGrid to ensure that the unit is on the latest firmware and configured for communication with Sol-Ark inverters.

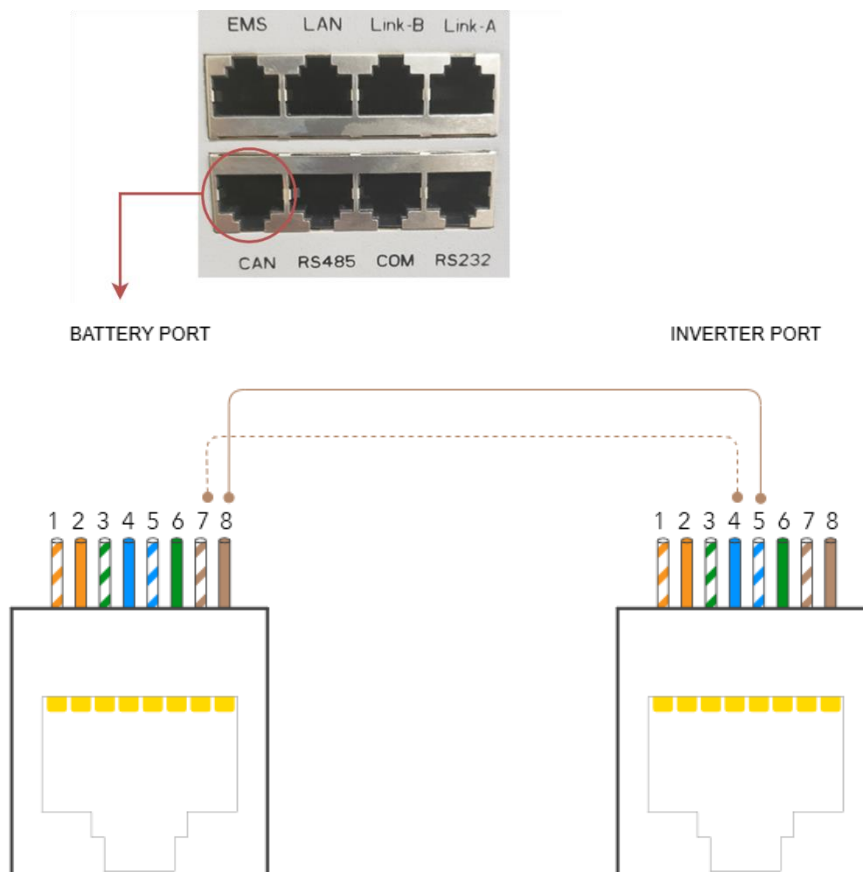

Liniotech

LTN051280A-B-GBP2

Follow these instructions for setting up Liniotech batteries and Sol-Ark inverters.

To ensure optimal performance and safety, consult Liniotech's comprehensive documentation for specifications and settings:

[Liniotech documentation](#)

Communications Installation and Setup Instructions

Custom RJ45 cable

No custom cable is needed.

Battery IDs and connections

1. Connect all batteries using the included RJ45 cables.
2. Use ports **RS485A** and **RS485B**, as shown here, to bridge the batteries together.
3. Set the DIP switch according to the battery manual. The master battery must be set as shown below, with #5 switched to **ON**.



Inverter programming and connections

1. Use the RJ45 cable to connect the **CAN IN** of the battery to the **CAN** communication port of the inverter, as shown at right.
2. Program the inverter with this battery's appropriate charge/discharge settings.
3. Enable **BMS Lithium Batt** and set its value to **00**.
4. (Optional) Turn on **BMS_Err_Stop** if you want the system to fault on loss of battery communication.





Pylontech

Follow these instructions for setting up Pylontech batteries with Sol-Ark inverters.

Pelio-L-5.12

Communications Installation and Setup Instructions

To ensure optimal performance and safety, consult Pylontech’s comprehensive documentation for the Pelio-L-5.12 specifications and settings:

[Pylontech Pelio-L-5.12 documentation](#)

1. A standard ethernet cable can be used for communication.
2. Set the DIP switch according to the battery manual. Switch **1** must be **ON**.
3. Connect the cable to the **CAN** port (8) on the Pelio-5.12 battery and the **Battery CAN Bus** port (or the **CAN** port for indoor-only units) on the Sol-Ark.
4. Program the inverter with the appropriate charge/discharge settings according to the specific battery manual and cable arrangement.
5. Enable **BMS Lithium Batt** and set its value to **00**.
6. (Optional) Turn on **BMS_Err_Stop** if you want the system to fault on the loss of battery communication. Pylontech recommends leaving on **BMS_Err_Stop** to protect their batteries.

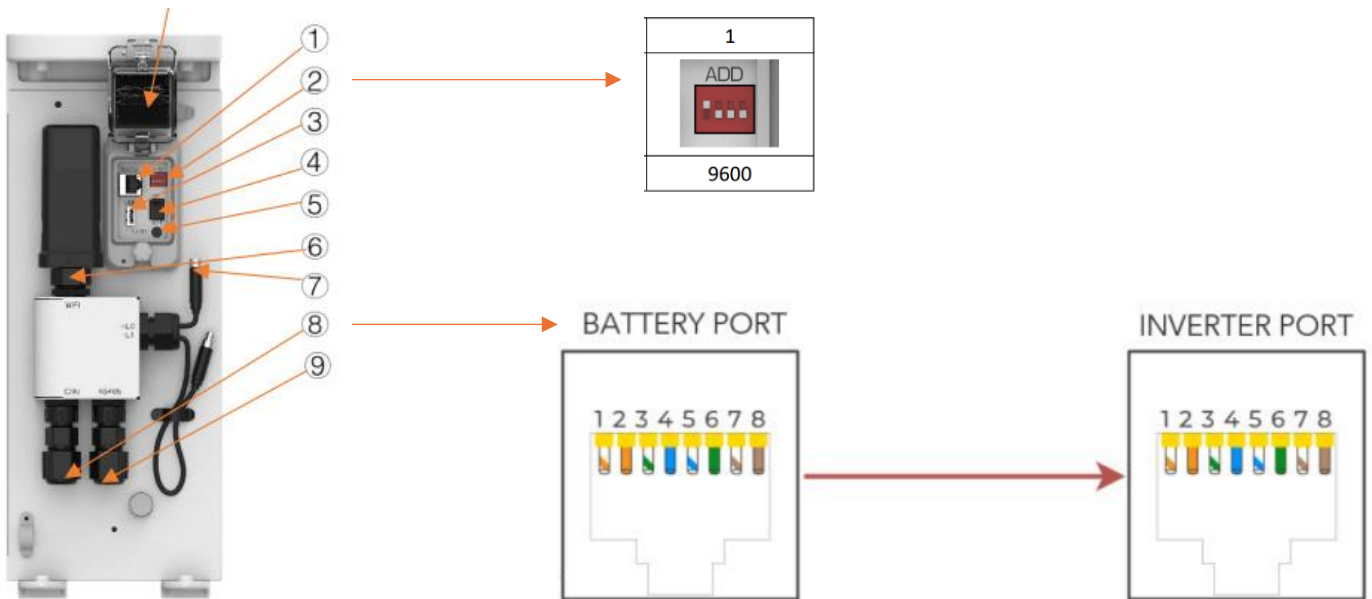



US3000C

To ensure optimal performance and safety, consult Pylontech’s comprehensive documentation for the US3000C specifications and settings:

[Pylontech US3000C documentation](#)

Communications Installation and Setup Instructions



You need a custom RJ45 cable for this setup.

Custom RJ45 cable

1. Create a custom cable that connects battery pins 4 (solid blue), 5 (white-blue), and 6 (solid green) to inverter port pins 4, 5, and 6 respectively.
2. On indoor models, pin 6 (solid green) needs to connect to pin 2 on the inverter.

Battery-inverter communication connections

Wire color	Battery (A/CAN) port	Inverter port
Solid blue	4	4
White-blue	5	5
Solid green	6	2 (indoor only) or 6 (outdoor only)

Battery IDs and connections

1. Connect all batteries with the RJ45 cable from Link Port 1 to Link Port 0. The first battery with Link Port 0 empty would be the “master” battery.
2. You can use up to 16 batteries with 1 “master” battery and 15 “slave” batteries.
3. Set the **ADD** switch according to the battery manual if more than one string of batteries is in the battery bank.



Inverter programming and connections

1. Connect the cable to the **A/CAN** port on the Pylontech master battery and the **Battery CANBus** port (outdoor-rated models) or the **CAN** port (indoor-rated models) on the Sol-Ark.
2. Program the inverter with the appropriate charge/discharge settings according to the specific battery manual.
3. Enable **BMS Lithium Batt** and set its value to **00**.
4. (Optional) Turn on **BMS_Err_Stop** if you want the system to fault on the loss of battery communication. Pylontech recommends leaving ON the **BMS_Err_Stop** to protect their batteries.

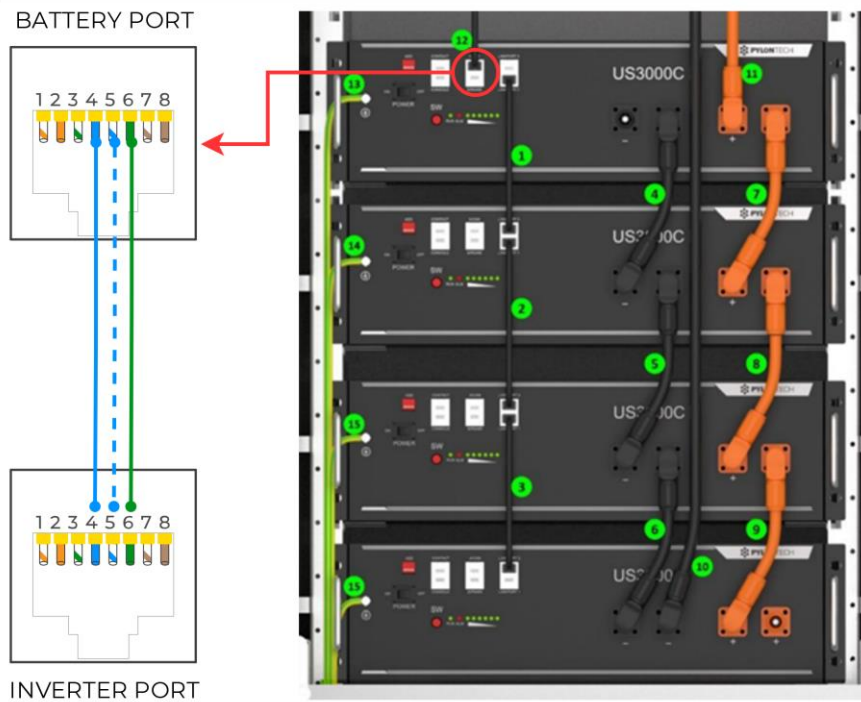



Pytes

Follow these instructions for setting up Pytes V5 batteries and Sol-Ark inverters.

To ensure optimal performance and safety, consult Pytes' comprehensive documentation for specifications and settings:

[Pytes documentation](#)

V5

Communications Installation and Setup Instructions

1. A standard ethernet cable can be used for communication.
2. Set the DIP switch according to the battery manual. Switch 1 and 5 must be on. See the diagram below for the configuration of the "master" battery.
3. Connect the cable to the **CAN** port on the Pytes V5 battery and the **Battery CANBus** port (or the **CAN** port for indoor-only units) on the Sol-Ark.
4. Program the inverter with the appropriate charge/discharge settings according to the specific battery manual and cable arrangement.
5. Enable **BMS Lithium Batt** and set its value to **00**.
6. (Optional) Turn on **BMS_Err_Stop** if you want the system to fault on the loss of battery communication. Pytes recommends leaving **ON** the **BMS_Err_Stop** to protect their batteries.

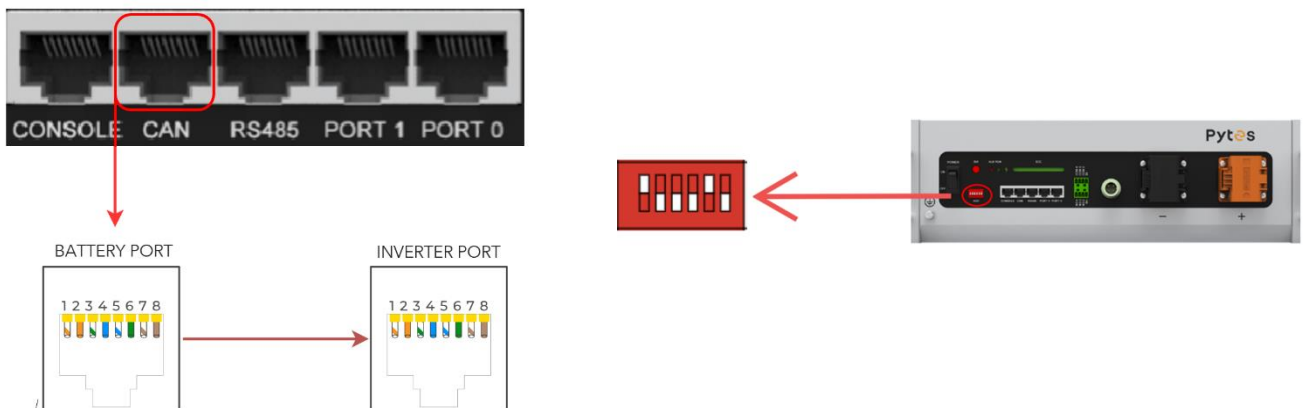



V16

Follow these instructions for setting up Pytes V16 batteries and Sol-Ark inverters.

Communications Installation and Setup Instructions

1. A standard ethernet cable can be used for communication.
2. Set the DIP switch according to the battery manual. Switch 1 and 5 must be on. See the diagram below for the configuration of the “master” battery.
3. Connect the cable to the COM port on the Pytes V16 battery and the Battery CANBus port (or the CAN port for indoor-only units) on the Sol-Ark.
4. Program the inverter with the appropriate charge/discharge settings according to the specific battery manual and cable arrangement.
5. Enable **BMS Lithium Batt** and set its value to **00**.
6. (Optional) Turn on **BMS_Err_Stop** if you want the system to fault on the loss of battery communication. Pytes recommends leaving ON the **BMS_Err_Stop** to protect their batteries.

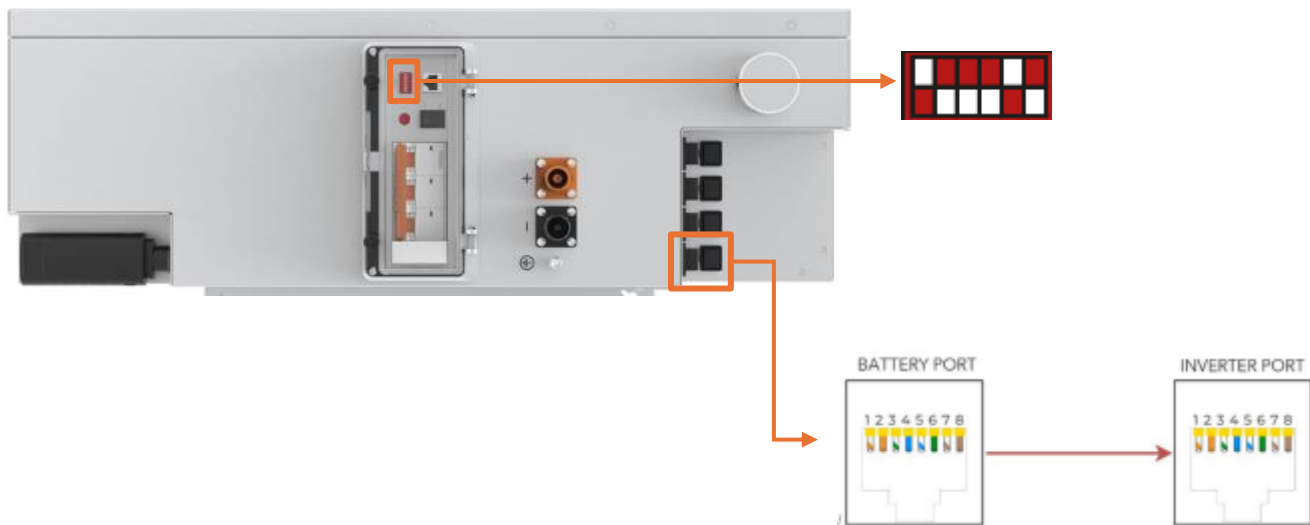



RENON

Follow these instructions for setting up Renon Xcellent Plus R-XC016161-H-US & Xtreme LV Series batteries and Sol-Ark inverters.

RENON Xcellent Plus R-XC016161-H-US

To ensure optimal performance and safety, consult Renon’s comprehensive documentation for Xcellent Plus R-XC016161-US specifications and settings:

[Renon Xcellent Plus R-XC016161-H-US](#)

Communications Installation and Setup Instructions

1. No custom cable is needed. A standard Ethernet cable can be used for communication.
2. Set the DIP switches for the **Inverter Dial Switch** on the “master” battery to the **UP** position for switches **1** and **2**.
3. Set the **Address Dial Switch** and **Function Dial Switch** on each stack according to the manufacturer’s manual.
4. Connect the communication cable to the **INV COM** port on the Xcellent Plus R-XC016161-US battery and the **Battery CANBus** port (or the **CAN** port for indoor-only units) on the Sol-Ark.
5. Program the inverter with the appropriate charge/discharge settings according to the specific battery and cable arrangement shown in the RENON manual.
6. Enable **BMS Lithium Batt** and set its value to **00**.
7. (Optional) Turn on **BMS_Err_Stop** if you want the system to fault on the loss of battery communication.

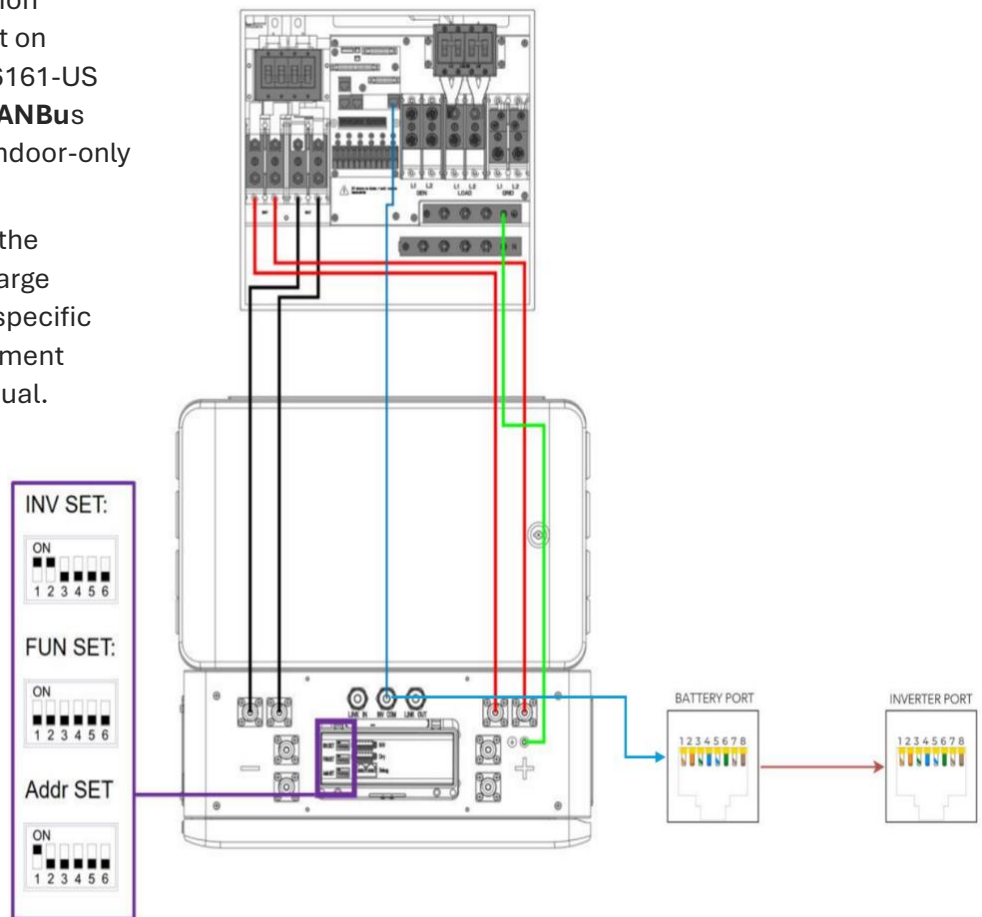



RENON Xtreme LV Series

To ensure optimal performance and safety, consult Renon’s comprehensive documentation for specifications and settings:

[RENON Xtreme LV Series documentation](#)



You need a custom RJ45 cable for this setup.

Communications Installation and Setup Instructions

Custom RJ45 cable

Create a custom RJ45 cable that connects battery port pins 6 (solid green), 7 (white-brown), and 8 (solid brown) to inverter port pins 6, 4, and 5 respectively.

Battery-inverter communication connections

Wire color	Battery (INV1) port	Inverter port
Solid green	6	6
White-brown	7	4
Solid brown	8	5

Battery IDs and connections

1. Set the DIP switches for the **Inverter Dial Switch** on the master battery to the UP position for switches 1 and 2.
2. Set the **Address Dial Switch** and **Function Dial Switch** on each stack according to the manufacturer’s manual.
3. Connect all top modules (if in parallel) together using an RJ45 cable between **Link A** and **Link B** ports (**Link B** on the “master” battery, **Link A** on the “slave” battery).
4. Power on the battery stack by pressing the Power button. If in parallel, turn on the “slave” units first, then the “master” last.



Inverter programming and connections

1. Connect the cable between the master battery's Main Control Module **INV 1** port and the inverter's **Battery CANBus** port (outdoor-rated models).
2. Program the inverter with the battery's appropriate charge and discharge settings.
3. Enable **BMS Lithium Batt** and set this value to **00**.
4. (Optional) Turn on **BMS_Err_Stop** if you want the system to fault in case of loss of battery communication.
5. If communication still needs to be established, contact Renon to verify the unit has the latest firmware and is configured for communication with Sol-Ark inverters.

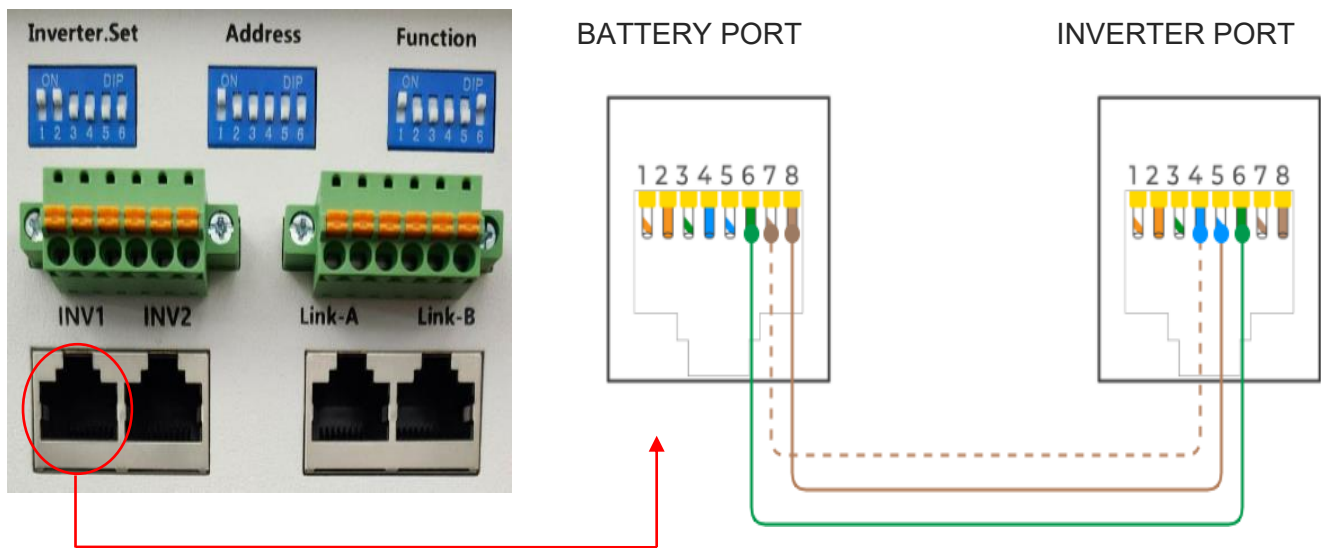



Soluna

10K PACK LV

Follow these instructions for setting up Soluna 10K PACK LV batteries and Sol-Ark inverters.

To ensure optimal performance and safety, consult Soluna’s comprehensive documentation for specifications and settings.

[Soluna Documentation](#)

Communications Installation and Setup Instructions

1. A standard ethernet cable can be used for communication.
2. Set the DIP switch according to the battery manual. See the diagram below for the configuration of the battery or batteries.
3. Connect the cable to one the **CAN 2** port on the Soluna 10K PACK LV battery and the **Battery CANBus** port (or the **CAN** port for indoor-only units) on the Sol-Ark.
4. Program the inverter with the appropriate charge/discharge settings according to the specific battery manual and cable arrangement.
5. Enable **BMS Lithium Batt** and set its value to **00**.
6. (Optional) Turn on **BMS_Err_Stop** if you want the system to fault on the loss of battery communication. Soluna recommends leaving **ON** the **BMS_Err_Stop** to protect their batteries from communications loss.

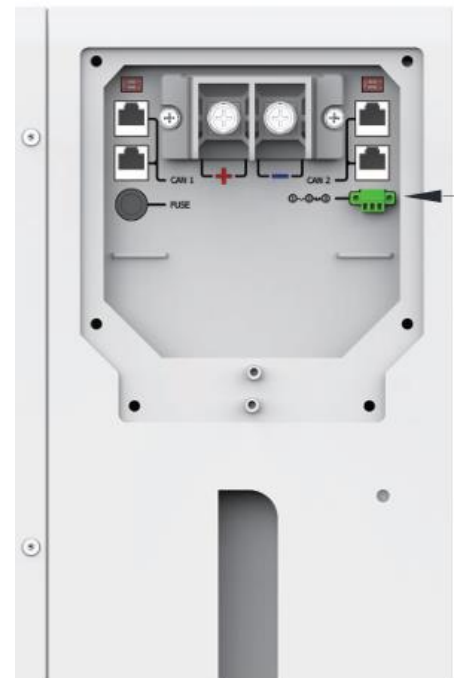
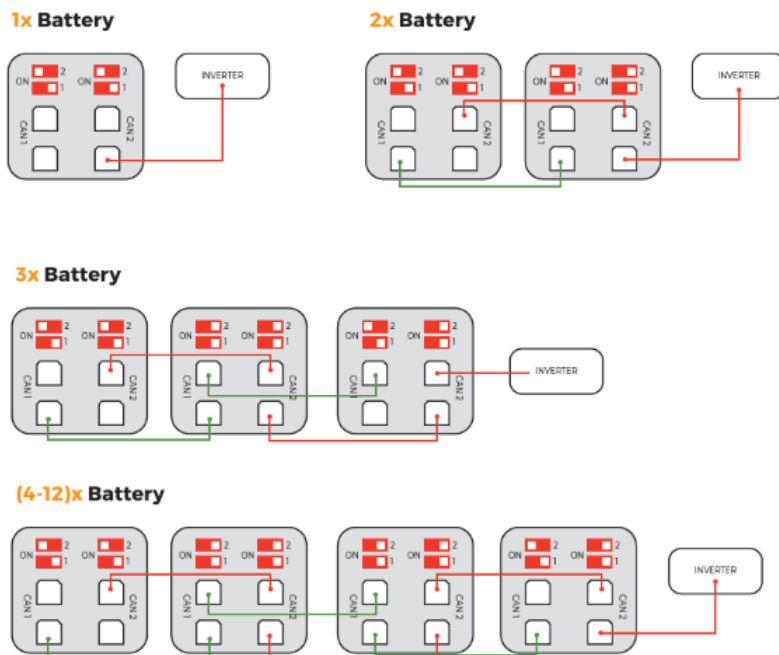



Volthium Energy

51.2-100-R-H

Follow these instructions for setting up Volthium Energy batteries and Sol-Ark inverters.

To ensure optimal performance and safety, consult Volthium’s comprehensive documentation for specifications and settings:

[Volthium Energy documentation](#)

Communications Installation and Setup Instructions

Custom RJ45 cable

No custom cable is needed.

Battery IDs and connections

1. Connect all batteries together with the provided RJ45 cables using the **Battery-Comm** ports. Either port can be used for each battery. Up to 15 batteries can be connected in parallel.
2. Set the DIP switches so that the battery communicating with the inverter is set as **ID 1**, and each unit behind it increases the follower ID by 1.

Note: Skip ID 2 (0010).

- Each DIP switch (1-4) represents a bit in the follower ID value, from right to left. For example: 13 (decimal) = 1101 binary = [1: UP, 2: UP, 3: DOWN, 4: UP]
- Decimal counting from 0 to 15 in binary format as a 4-bit nibble (half byte):

0 1 2 3 4 5 6 7 8 9 10 11 12 13 14 15 dec

0000 0001 0010 0011 0100 0101 0110 0111 1000 1001 1010 1011 1100 1101 1110 1111 binary

Inverter programming and connections

1. Connect a standard CAT5/6 cable between the **CAN** port on the “master” battery and the **Battery CANBus** port (outdoor-rated models) or the **CAN** port (indoor-rated models) on the Sol-Ark.
2. Turn on the power buttons of the batteries.
3. Turn on the breakers of the batteries and inverter.
4. Use a thin tool to press the **RST** button in any of the batteries to turn all on. You can now turn on the inverter if it is not on already.
5. Program the inverter with the appropriate charge/discharge settings according to the specific battery manual and cable arrangement.
6. Enable **BMS Lithium Batt** and set its value to **00**.
7. (Optional) Turn on **BMS_Err_Stop** if you want the system to fault on loss of battery communication.

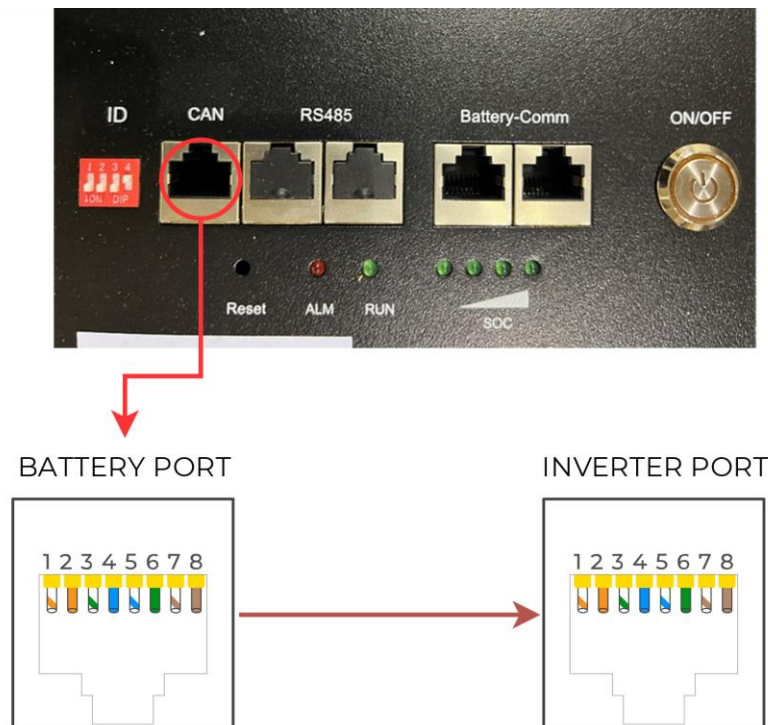



Proven Storage Partners

These battery manufacturers have been proven to work with Sol-Ark inverters, but they have not yet been certified by Sol-Ark.

Manufacturer ³	Compatible Battery Model	BMS Lith Batt	Custom cable required?
Fortress	eFlex max eVault Max	00	Yes
POWERSYNC	LFP3250-LV512100	00	No
Storz Power	LFP48100-5KWH	CAN mode 00 RS485 mode 01	Yes

³Trademarks, logos and tradenames of battery manufacturers are used with permission.



Fortress

eFlex Max and eVault Max

Follow these instructions for setting up Fortress batteries and Sol-Ark inverters.

To ensure optimal performance and safety, consult the comprehensive documentation from Fortress for specifications and settings:

[Fortress documentation](#)

eFlex Max



You need a custom RJ45 cable for the Evault Max.

Communications Installation and Setup Instructions

Custom RJ45 cable

Battery-inverter communication connections

Wire color	Battery (CAN) port	Inverter port
White-orange	CAN1_H	4
Solid orange	CAN1_L	5
White-green	GROUND	6

1. Install the battery to battery communication using regular ethernet cables.
2. After daisy-chaining the **battery-to-battery communication cables**, one **unused Ethernet port** will remain at **each end of the battery bank**.
3. Use either one of the empty ports for the battery-to-inverter communication. Connect the custom cable to the **CAN RS485** port and **Battery CANbus** port of the inverter.
4. Connect the **CANbus** terminator to the other (remaining) empty port of the battery bank.
5. Turn on the batteries and inverter.
6. Program the inverter with the appropriate charge/discharge settings according to the specific battery manual and cable arrangement.
7. Enable **BMS Lithium Batt** and set its value to **00**.
8. (Optional) Turn on **BMS_Err_Stop** if you want the system to fault on loss of battery communication.



EVault Max



You need a custom RJ45 cable for the Evault Max.

Communications Installation and Setup Instructions

Custom RJ45 cable

Create a custom RJ45 cable that connects battery port pins **1** (solid blue), **2** (white-blue), and **3** (solid green) to inverter port pins **4**, **5**, and **6** respectively.

Battery-inverter communication connections

Wire color	Battery (CAN) port	Inverter port
Solid blue	CAN1_H	4
White-blue	CAN1_L	5
Solid green	GROUND	6

1. With the batteries powered OFF and their DC breakers in the OFF position, connect the battery-to-battery communication cables in a daisy-chain configuration using the bi-directional COM Parallel ports (IN/OUT). Make sure that the USB port is empty and always remains empty.
2. Turn on one battery at a time and use the battery touchscreen to enter the correct battery ID and the protocol ID **2** on all of them.
 - a. Start with the battery that will be connected to the inverter via the battery-inverter communication cable. Assign battery IDs in ascending order (1 for the first battery, 2 for the second, etc.). For systems with only one eVault Max battery, the battery ID must be set to **0**.
3. Connect the custom cable to the Evault Max **CAN** port and the **Battery CANbus** port.
4. The CAN Bus terminator switch on the battery must be set to **120 Ω**.
If the system includes more than one battery, set the switch to **120 Ω** on the **first and last batteries in the sequence**, and set the switch to **OFF** on all **other batteries** in the system.
5. Turn on the breakers of the batteries and inverter.
6. Program the inverter with the appropriate charge/discharge settings according to the specific battery manual and cable arrangement.
7. Enable **BMS Lithium Batt** and set its value to **00**.
8. (Optional) Turn on **BMS_Err_Stop** if you want the system to fault on loss of battery communication.



POWERSYNC

LFP3250-LV480100SP

Follow these instructions for setting up PowerSync batteries and Sol-Ark inverters.

To ensure optimal performance and safety, consult PowerSync’s comprehensive documentation for specifications and settings:

[PowerSync documentation](#)

Communications Installation and Setup Instructions

Custom RJ45 cable

No custom cable is needed.

Battery IDs and connections

1. Set the DIP switches on the battery per the manual and your battery configuration.
2. Connect all batteries with the included short RJ45 cables, connecting each battery via their RS485 ports.

Inverter programming and connections

1. CAN mode cable: Using a standard RJ45 connector-based CAT5/CAT6 Ethernet cable (all leads straight through), connect the master battery’s **CAN** port to the inverter’s **Battery CANBus** port (outdoor-rated only) or the **CAN** port (indoor-rated models).
2. Turn on the batteries using the breaker labeled **Master Switch**.
3. Program the inverter with this battery’s appropriate charge/discharge settings.
4. Enable **BMS Lithium Batt** and set its value to **00**.
5. (Optional) Turn on **BMS_Err_Stop** if you if you want the system to fault on loss of battery communication.

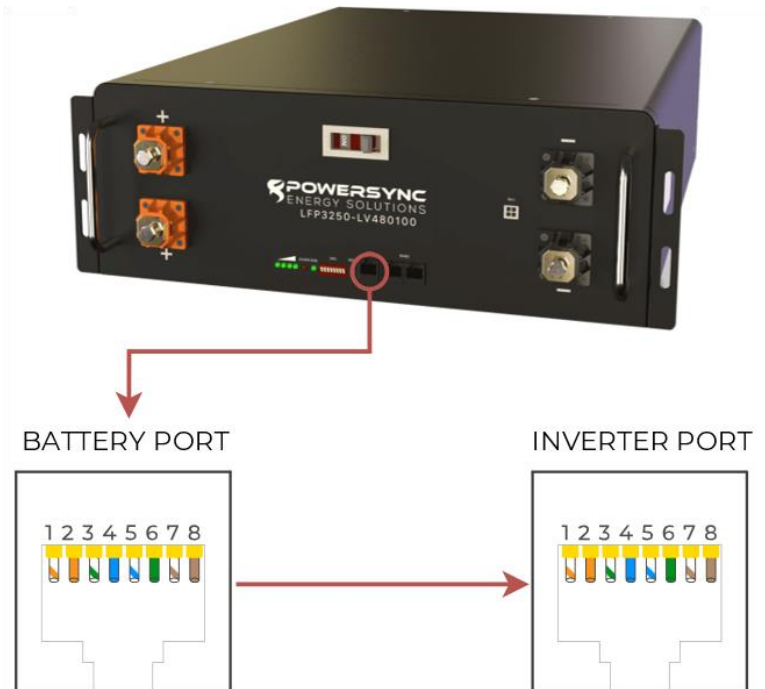



Storz Power

LFP48100-5KWH

Follow these instructions for setting up Storz Power batteries and Sol-Ark inverters.

To ensure optimal performance and safety, consult Storz Power’s comprehensive documentation for specifications and settings:

[Storz Power website](#)



Make a custom cable as shown below or get it from Storz Power. Communications installation and setup instructions are updated for newer battery models on the Storz Power website

Communications Installation and Setup Instructions

Custom RJ45 cable

Create two custom cables:

- 1. Custom cable #1:** On one end of the RJ45 cable, cut all cables except for pins 4 (solid blue) and 5 (white-blue).

Custom cable #1: Battery-inverter communication connections

Wire color	Battery (RS485) port	Inverter port
Solid blue	4	2
White-blue	5	1
Solid green	6	6

- 2. Custom cable #2:** On one end of the RJ45 cable, cut all cables except for pins 7 (white-brown) and 8 (solid brown).

Custom cable #2: Battery 1-battery 2 communication connections

Wire color	Battery 1 (RS485) port	Battery 2 (RS485) port
White-brown	7	7
Solid brown	8	8

The sides with custom pinouts will be connected to the Quick Link.



Custom RJ45 cable (Modbus RS485 mode – legacy)

Create a custom cable that connects battery port pins **1** (white-orange) and **2** (solid orange) to inverter port pins **1** or **8** and **2** or **7**, respectively.

Battery-inverter communication connections

Wire color	Battery (RS485) port	Inverter port
White-orange	1	1 or 8
Solid orange	2	2 or 7

Battery IDs and connections

- Use the DIP switches on the batteries so that the battery connected to the inverter is set as follower 1 (0001), and each unit behind it increases the follower ID by 1 to be assigned. Each DIP switch (1-4) represents a binary digit (bit) in the follower ID with a value of 1 or 0.
- Decimal counting from 0 to 15 in binary format as a 4-bit nibble (half byte):
- 0 1 2 3 4 5 6 7 8 9 10 11 12 13 14 15 dec
- 0000 0001 0010 0011 0100 0101 0110 0111 1000 1001 1010 1011 1100 1101 1110 1111 binary
For example: to set the DIP switch to decimal 13 = 1101 binary: [1: ON, 2: ON, 3: OFF, 4: ON]
- Connect all batteries with the RJ45 cable so they are in parallel.

For **CAN** communications, connect battery Custom Cable #2 between the battery set to Master (**ID: 00**) and Battery 2 (**ID: 01**).

Inverter programming and connections

- Connect this cable between the battery to the inverter's:
 - (CAN mode): **Battery CANBus** port using Custom Cable #1, with the battery set to **ID:00**
 - (RS485 mode): **Battery CANBus** port (outdoor-rated models) or **RS-485** port (indoor-rated models), with the battery set to **ID:01**
- Program the inverter with this battery's appropriate charge/discharge settings.
- Enable **BMS Lithium Batt** and set its value to:
 - (CAN mode): **00**
 - (RS485 mode): **01**
- (Optional) Turn on **BMS_Err_Stop** if you want the system to fault on the loss of battery communication. This may happen more frequently since the Storz Power batteries do not feature ground connections.

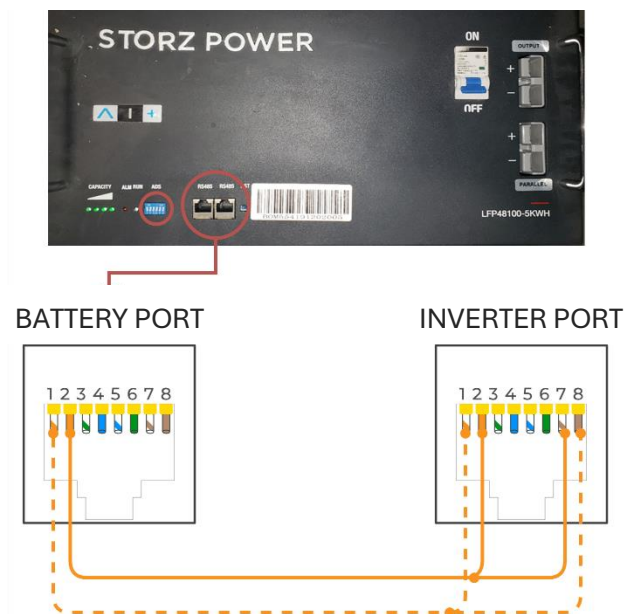



Storz Battery Modbus/RS-485 Screen

1	2	3	4	5				
55.91 V	0.00 A	23.5 C	100%	208Ah				
56.0V	48.0V	200A	208A	0x00 0x00				
6	7	8	9	10				
1	0.00 V	0.00 A	0.0 C	0.0%	0.0Ah	0.0V	0.0A	0 0 0
2	55.91 V	0.00 A	24.0 C	100.0%	103.0Ah	56.0V	100.0A	0 0 0
3	55.91 V	0.00 A	23.0 C	100.0%	105.0Ah	56.0V	100.0A	0 0 0
4	0.00 V	0.00 A	0.0 C	0.0%	0.0Ah	0.0V	0.0A	0 0 0
5	0.00 V	0.00 A	0.0 C	0.0%	0.0Ah	0.0V	0.0A	0 0 0
6	0.00 V	0.00 A	0.0 C	0.0%	0.0Ah	0.0V	0.0A	0 0 0
7	0.00 V	0.00 A	0.0 C	0.0%	0.0Ah	0.0V	0.0A	0 0 0
8	0.00 V	0.00 A	0.0 C	0.0%	0.0Ah	0.0V	0.0A	0 0 0
9	0.00 V	0.00 A	0.0 C	0.0%	0.0Ah	0.0V	0.0A	0 0 0
10	0.00 V	0.00 A	0.0 C	0.0%	0.0Ah	0.0V	0.0A	0 0 0
11	0.00 V	0.00 A	0.0 C	0.0%	0.0Ah	0.0V	0.0A	0 0 0
12	0.00 V	0.00 A	0.0 C	0.0%	0.0Ah	0.0V	0.0A	0 0 0
13	0.00 V	0.00 A	0.0 C	0.0%	0.0Ah	0.0V	0.0A	0 0 0



Note: Sol-Ark recommends that if establishing communication with Storz batteries, be sure to have the inverter firmware upgraded to Comm v143F or higher, and the latest primary and follower MCU versions.

The image shows the **Li Batt Info** screen when communicating via Modbus/RS-485 (all other **BMS Lithium Batt** modes).

- Battery Voltage:** Real-time voltage measured between the battery terminals.
- Battery Current:** Real-time current flowing into or out of battery's + terminal. (negative/positive sign respectively).
- Battery Temp:** Real-time temperature measured at the BMS.
- SOC:** State of charge remaining in the battery according to the BMS.
- Total Capacity:** Total Amp-Hour capacity connected to the inverter. Not present for all batteries.
- Battery Charge Voltage:** The inverter should charge the battery to the target charge voltage.
- Battery Empty Voltage:** Minimum voltage to which the inverter should discharge the battery.
- Charge Current Limit:** Maximum allowable current into the battery.
- Discharge Current Limit:** Maximum allowable current out of the battery.
- Alarms:** Displays any alarm codes from the battery (manufacturer specific).
- Battery Data Chart:** This table lists individual information from each connected battery up to a maximum of 12 batteries. Not all manufacturers utilize this feature.



Note: Line 1 is never populated. The first battery is always displayed on line 2.



Disclaimer

This *Battery Integration Guide* is intended to provide general assistance with the integration of third-party batteries and Sol-Ark manufactured hybrid inverters. It is not intended to substitute for, or to replace, the guidance or services of trained installers, engineers or other specialists that are responsible for system installation, design, testing and performance. It is also not intended to, and should not, replace or modify any of the technical, support or other information made available by the Battery manufacturer, including information related to safety and performance established by the Battery manufacturer. You are urged to consult with the Battery manufacturer and those persons responsible for installation, testing and system performance before undertaking any of the integration steps referred to in this Guide. In-depth configurations, step-by-step instructions, troubleshooting, and verification of operational parameters are not addressed in this Guide and are outside the scope of this Guide.

This *Battery Integration Guide* is provided “as is,” without charge, and is intended solely for general informational purposes without any right or presumption of reliance. Sol-Ark does not guarantee the results obtained by use of this battery integration guide nor does Sol-Ark provide any warranty, whether express, implied or statutory, including warranties of merchantability, quality, fitness for a particular purpose, title, non-infringement of intellectual property rights, accuracy, system integration, timeliness or satisfactory quality, regarding any product other than sol-ark manufactured products. Sol-Ark is not responsible, and offers no warranty, for, or with respect to, any battery product that is not manufactured by Sol-Ark.

Your sole and exclusive remedy for any defects, or other issues associated with, or related to, a battery product is limited and restricted solely to the manufacturer warranty provided by the manufacturer of that battery. Modifications, updates, or other changes made by the battery manufacturer to a battery product, including firmware, software or hardware modifications, updates or other changes, may affect information provided in this battery integration guide and may make it inapplicable. Any of those modifications, updates or other changes may also adversely affect use of the proposed battery with Sol-Ark products or may make any integration impractical, inadvisable or improper. You are solely responsible for any integration and should confirm with the battery manufacturer that no such modifications, updates or other changes have been made by the battery manufacturer.

This *Battery Integration Guide* assumes the accuracy and completeness of information made available to Sol-Ark as of the effective date on the first page of this guide, and Sol-Ark assumes no responsibility if that information was inaccurate or incomplete in any respect or if that information changes in any way after the effective date (including through software updates). This Guide is not intended to, and does not, supersede any instructions or directions that you may have received from the manufacturer of the battery, and is only intended to supplement those instructions or directions. Sol-Ark is not liable for any damages resulting from your use of this battery integration guide and, to the fullest extent permitted by applicable law, hereby expressly and unconditionally disclaims liability for any and all indirect, incidental, exemplary, punitive or consequential damages.



If you are uncertain about implementing or using any of the information contained in, or made available by, this Guide, you are urged not to continue with this Guide and immediately to contact the Battery manufacturer or Sol-Ark product support. This Guide does not modify, extend or change the terms of any warranty that may be applicable to your Sol-Ark products, and you should carefully consult those warranty terms to ensure that you may not be voiding or violating those warranty terms if you undertake any of the actions referred to in this Guide. In addition, you should never undertake or engage in any integration, repair or evaluation process unless and until your product has been fully and completely powered down and you have confirmed that the product is not charged in any manner.

Any action related to the information included in this Guide shall be governed by the internal laws of the State of Texas, United States of America, without giving effect to any conflicts of laws principles. Any action, suit, or other legal proceeding that is commenced to resolve any matter related to this Guide shall be commenced solely and exclusively in a state court sitting in Collin County, Texas (or, if appropriate, a federal court located within Collin County in the Eastern District of Texas), and you hereby consent to the personal jurisdiction of those courts.

Note: Sol-Ark does not offer technical support related to battery communications for battery models not specifically listed in this Guide or for batteries with respect to which modifications, updates, or other changes have been made, as noted above, after the Effective Date of this Guide.

Sol-Ark assumes no responsibility for any of those modifications, updates, or other changes or to inform itself of any of those modifications, updates, or other changes.

The warranty does not cover damage caused by any battery that is not specifically listed in Sol-Ark's *Low Voltage Battery Integration Guide*, and Sol-Ark hereby disclaims and excludes coverage for damage caused by any battery not included herein.¹

This Guide is intended solely for **Low-Voltage Hybrid Sol-Ark Inverters** and should not be used or referenced for any other types of Sol-Ark inverters.

¹ Trademarks, logos, and tradenames of battery partners have been used under license and with permission and are subject to copyright by the owners thereof. Any information regarding battery performance, installation or other matters regarding integration and documentation used in this Guide has been provided to Sol-Ark by the manufacturer, and Sol-Ark has relied on the accuracy and completeness of that information and documentation. Sol-Ark assumes no responsibility to update this Guide to reflect any modifications, updates or changes to the information and documentation provided by any battery manufacturer, and you are urged to refer to the most recent information and documentation made available by any battery manufacturer before undertaking any installation or integration of a battery product.

